

# PSVAL HT

## Piston Valve (DN50-250)

### Description

Forbes Marshall Piston Valves, PSVAL, provide perfect tightness and durable stability on different media such as steam, superheated steam, heat transfer fluid, water and compressed air.

### Sizes and Pipe Connection

- DN 50 / 65 / 80 / 100 / 125 / 150 / 200 / 250  
Flanged to class 150 / 300
- DN 50 / 65 / 80 / 100 / 125 / 150 / 200 / 250  
Flanged to PN16 / PN25 / PN40

For higher sizes DN 250 and 300 contact Forbes Marshall

### Body design conditions : DN 50-250 Class 150 Flanged ends

Maximum allowable pressure	19.6 bar g at 38 deg C
Maximum operating pressure	14 bar g at 195 deg C
Maximum operating temperature	425 deg C at 5.5 bar g
Cold hydraulic test pressure	21 bar g (IBR requirement)

### Body design conditions : DN 50-250 Class 300 Flanged ends

Maximum allowable pressure	51.1 bar g at 38 deg C
Maximum operating pressure	41.7 bar g at 253 deg C
Maximum operating temperature	425 deg C at 28.8 bar g
Cold hydraulic test pressure	62.5 bar g (IBR requirement)

### Body design conditions : DN 50-200 PN 16 Flanged End

Maximum allowable pressure	16 bar g at 38 deg C
Maximum operating pressure	16 bar g at 204 deg C
Maximum operating temperature	425 deg C at 9.1 bar g
Cold hydraulic test pressure	24 bar g

### Body design conditions : DN 50-150 PN 25 Flanged End

Maximum allowable pressure	25 bar g at 38 deg C
Maximum operating pressure	24.6 bar g at 226 deg C
Maximum operating temperature	425 deg C at 14.2 bar g
Cold hydraulic test pressure	37 bar g

### Body design conditions : DN 50-200 PN 40 Flanged End

Maximum allowable pressure	40 bar g at 38 deg C
Maximum operating pressure	39 bar g at 250 deg C
Maximum operating temperature	425 deg C at 22.8 bar g
Cold hydraulic test pressure	59 bar g

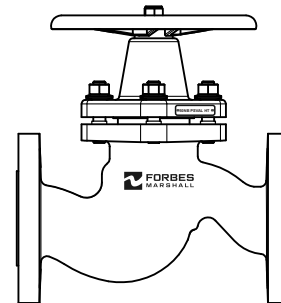

DN 50

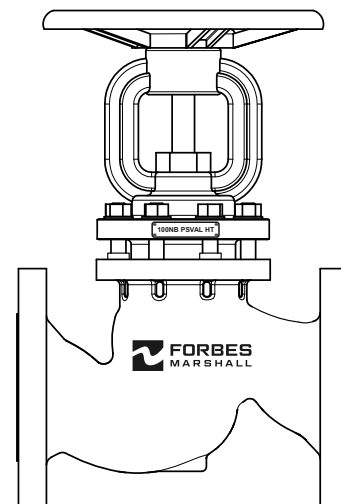

DN 65 to 250

### Operating Range

#### Class 150-300

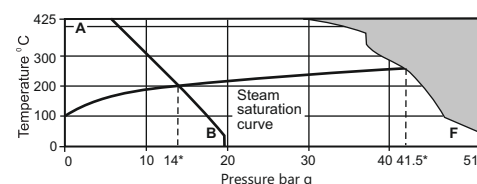

The product must not be used in this region.

A - B Flanged ANSI 150 A - F Flanged ANSI 300

\* PMO- Maximum operating Pressure

#### DIN PSVAL

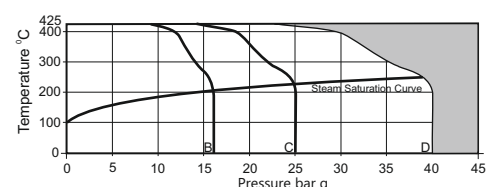

The product must not be used in this region.

A - B Flanged PN 16 A - C Flanged PN 25 A - D Flanged PN 40

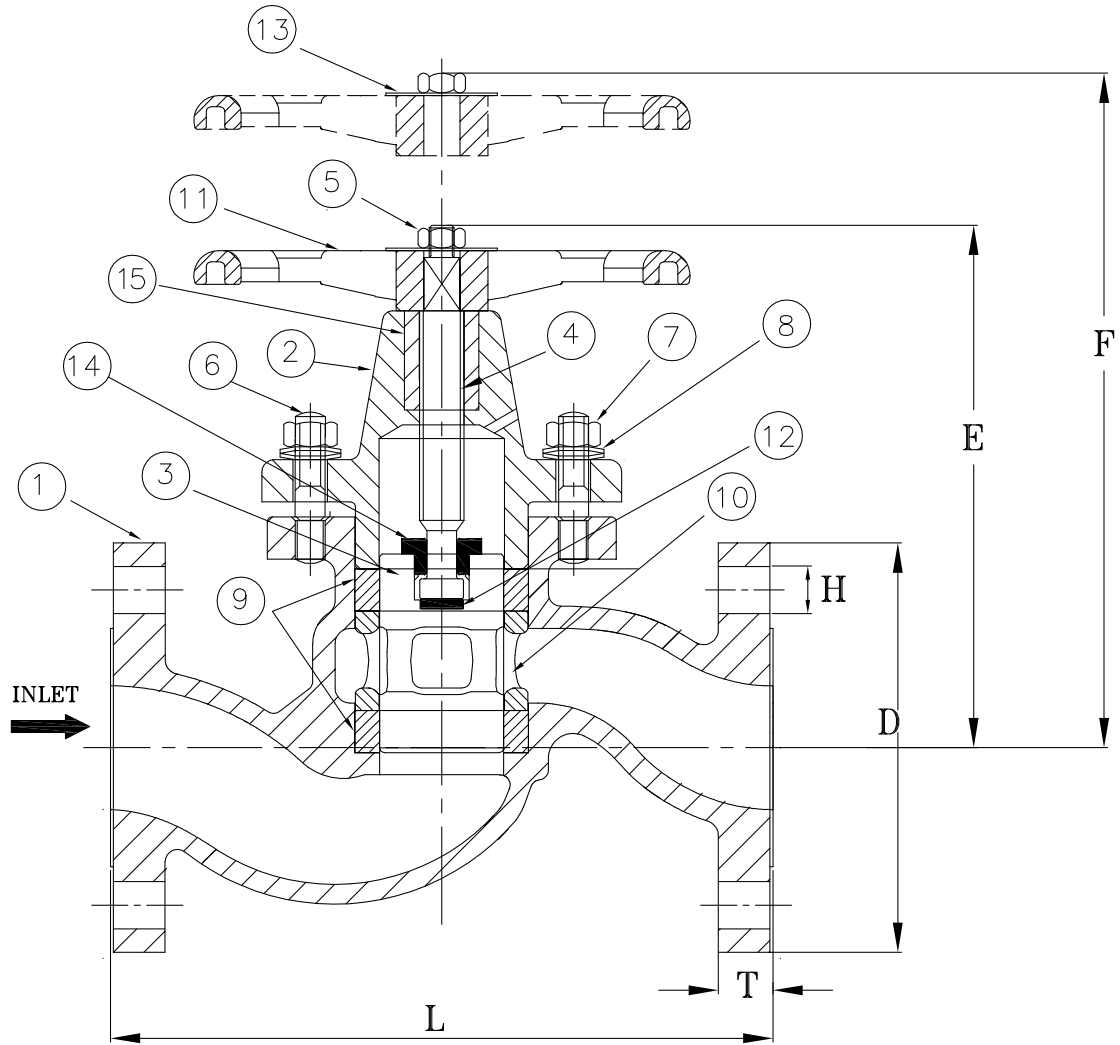

DN 50 Piston valve : always open /close valve fully  
do not use valve key

Dimensions (approx. in mm) : Size DN 50

ANSI Class	L	D	PCD	H	No. of Holes	T	E	F	WEIGHT (approx)
150	203	152	121	19	4	19	210	262	14.5 kg
300	267	165	127	19	8	22	210	262	17.5 kg
PN 16/25	230	165	125	18	4	18	210	262	14.5 kg
PN 40	230	165	125	18	4	20	210	262	17.5 kg

Material: DN 50

Sr. No.	Description	Material	Standard
1	Body	Cast Steel	ASTM A 216 Gr.WCB
2	Bonnet	Forged Carbon Steel	ASTM A 105N
3	Piston	Stainless Steel	ASTM A 276 TYPE 304
4	Spindle	Stainless Steel	ASTM A 276 TYPE 410
5	Nyloc Nut	Carbon Steel	
6	Stud	Carbon Steel	ASTM A193 Gr. B7
7	Nut	Carbon Steel	ASTM A 194 Gr.2H
8	Belleville Washer	Spring Steel	51CrV4
9	Sealing stack	S/S Reinforced Graphite	
10	Spacer	Stainless Steel	ASTM A 743 Gr.CA15
11	Handwheel	SG Iron	
12	Thrust Plate	Stainless Steel	ASTM A 276 TYPE 420
13	Name Plate	Stainless Steel	ASTM A 240 TYPE 304
14	Split Nut	Carbon Steel	AISI 4140
15	Bush	Bronze	

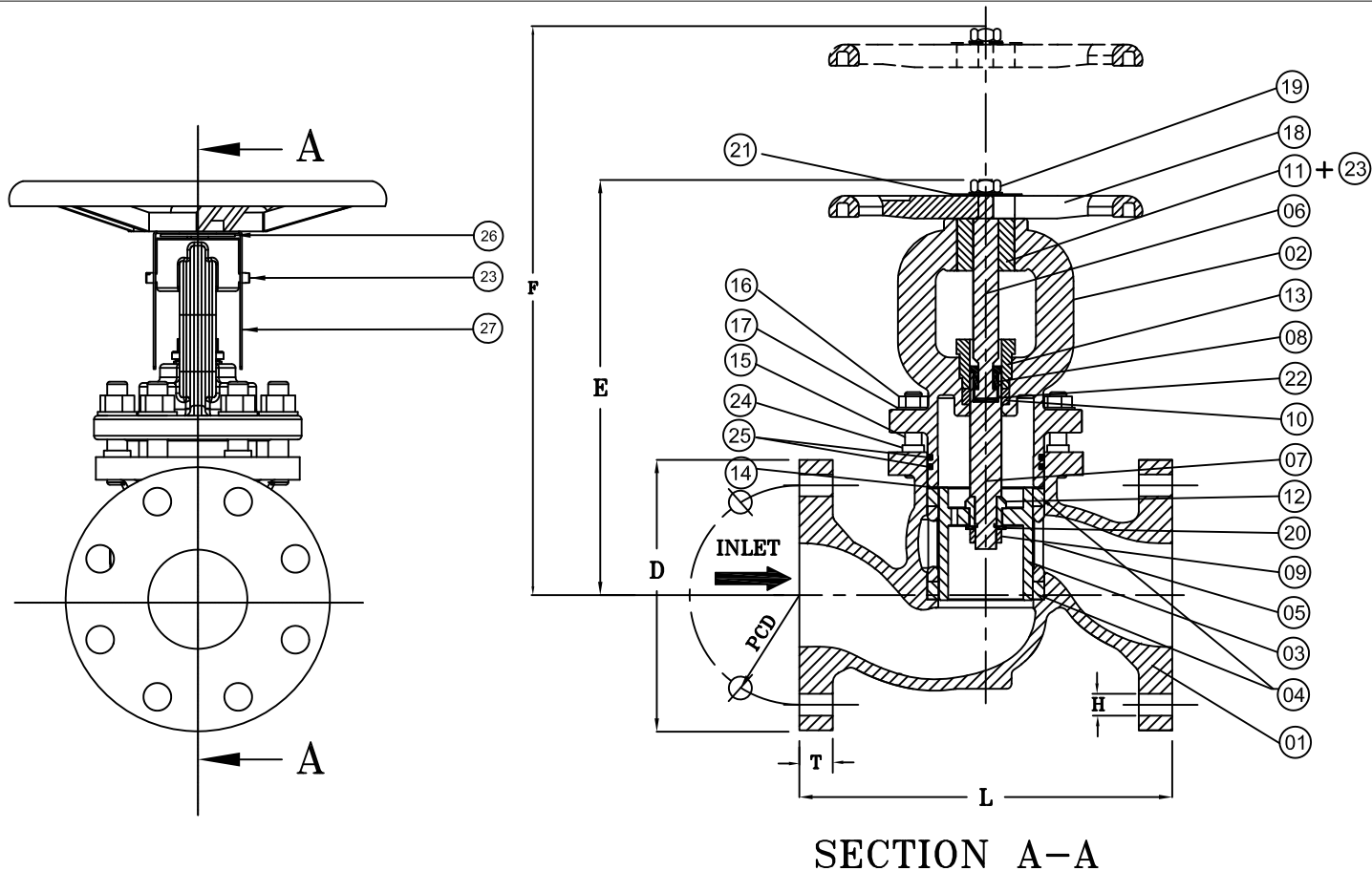

DN 65-250 : always open / close valve fully  
Do not use 'F' Key

Material: DN 65-250

Sr.No.	Description	Material	Standard
1	Body	Cast Steel	ASTM A 216 Gr.WCB
2	Bonnet(125-250NB)	Cast Steel	ASTM A 216 Gr.WCB
	Bonnet(65-80-100NB)	Forged Carbon Steel	ASTM A 105N
3	Piston	Stainless Steel	ASTM A 351 CF8
4	Body sealingstack	S/S ReinforcedGraphite	
5	Spacer	Stainless Steel	ASTM A 743 CA 15
6	Spindle	Stainless Steel	ASTM A 276 Type 410
7	Stem	Stainless Steel	ASTM A 276 Type 304
8	Split Nut	Carbon Steel	Fe37 / AISI 4140
9	LH Nut	Stainless Steel	ASTM A 276 Type 304
10	Gland SealingStack	S/S ReinforcedGraphite	
11	Threaded Bush	Bronze	
12	Back Seat	Stainless Steel	ASTM A 276 Type 410
13	Hex.Gland Nut	Stainless Steel	ASTM A 276 Type 410
14	Bonnet SealingRing	Graphite	
15	Stud	Carbon Steel	ASTM A 193 Gr.B7
16	Nut	Carbon Steel	ASTM A 194 Gr.2H
17	Beleville Washer	Spring Steel	51CrV4
18	Handwheel	S.G. Iron	
19	Nyloc Nut	Carbon Steel	
20	Name Plate	Stainless Steel	ASTM A 240 TYPE 304
21	Thrust Plate	Stainless Steel	ASTM A 276 TYPE 420
22	Washer	Stainless Steel	ASTM A 240 TYPE 304
23	Stopper Screw	Stainless Steel	ASTM A 276 TYPE 304
24	Gap Ring(100-250NB)	Stainless Steel	ASTM A 276 Type 410
25	GP Flexible Rope(100-250NB)	Graphite	
26	Spindle Circular Plate	Stainless Steel	ASTM A 276 TYPE 304
27	On-Off Indicator Plate	Stainless Steel	ASTM A 240 TYPE 304

**Dimensions (approx. in mm) : Size DN 65 to 250**

Sizes (DN)	Pressure Class	L	D	PCD	H	NO. OF HOLES	T	E	F	Approx. Weight (Kg)
65	CLASS 300	292	191	149	22	8	25	335	400	31
65	CLASS 150	216	178	140	19	4	22	335	400	27
65	PN 16 / 25	290	185	145	18	8	18	335	400	27
65	PN40	290	185	145	18	8	22	335	400	31
80	CLASS 300	318	210	168	22	8	28	320	384	37
80	CLASS 150	241	191	152	19	4	24	320	384	31
80	PN 16 / 25	310	200	160	18	8	24	320	384	31
80	PN 40	310	200	168	18	8	20	320	479	37
100	CLASS 300	356	254	200	22	8	32	395	479	58
100	CLASS 150	292	229	191	19	8	24	395	479	47
100	PN 16 / 25	350	220	180	20	8	18	395	479	47
100	PN 40	350	235	190	24	8	22	395	479	58
125	CLASS 300	400	280	235	22	8	35	446	540	87
125	CLASS 150	356	254	216	22	8	24	446	540	70
125	PN 16 / 25	400	250	210	18	8	22	446	540	70
125	PN 40	400	270	220	26	8	26	446	540	87
150	CLASS 300	445	318	270	22	12	37	486	598	117
150	CLASS 150	406	279	241	22	8	26	486	598	90
150	PN 16 / 25	480	285	240	22	8	22	486	598	90
150	PN 40	480	300	250	26	8	28	486	598	117
200	CLASS 300	559	381	330	25	12	41	591	728	210
200	CLASS 150	495	343	298	22	8	28	591	728	164
200	PN 16	600	340	295	22	12	24	591	728	164
200	PN 40	600	375	320	30	12	34	591	728	210
250	CLASS 300	622	455	381	26	16	48	653	813	340
250	CLASS 150	622	405	362	25	12	31	653	813	300
*250	PN 16	730	405	355	26	12	26	653	813	340
*250	PN 40	730	450	385	33	12	38	653	813	370

**How to Order**

Example: DN 50 Piston Valve with Flanged to Class 150

**Installation**

The valve is designed for installation in a vertical or horizontal line with inlet as per the arrow direction. To open the valve turn hand wheel till it stops at the top and to close, turn hand wheel till it touches the bonnet. Do not use "F" key. If any leakage is observed during operation at the outlet, close valve fully and tighten opposite nuts equally half or one turn until leakage stops.

**Ensure that water hammer is not present in the lines under any circumstances. This can be done by gradually charging the line and draining all the residual condensate through drain valves every time the line is charged with steam. Heavy water hammer may permanently damage the piston valve**

**Safety Information**

Pressure : Before attempting any maintenance of the valve, ensure that pressure is isolated and safely vented to atmosphere. Do not assume that the system is depressurized even when a pressure gauge indicates zero.

**Maintenance**

Use Molykote M30 oil for lubrication. For DN 50 size lubricate spindle regularly through bonnet hole and spindle threads. For DN 65-250 lubricate frequently through spindle threads, split nut and stem.

**Available Spares**

Refer Piston Valve user manual for available spares.

**How to Order Spares**

Order spares as per the code no. specified in the user manual.

**Kv Values**

Size (DN)	65	80	100	125	150	200	250	300
Kv	51	77	131	194	221	438	650	955

**Recommended Tightening Torques For Bonnet Nut**

Sr. No.	Size (DN)	Torque (Nm)
1	50	15-20
2	65	50 - 60
3	80	
4	100	70 - 80
5	125	
6	150	80 - 90
7	200	
8	250	110-120
9	300	

**For Gland Nut**

Sr. No.	Size (DN)	Torque (Nm)
1	65	35-45
2	80	
3	100	75 - 85
4	125	
5	150	85-95
6	200	
7	250	100-115
8	300	

### Piston Valve Operating Guidelines

1. Flush the line properly before taking the Piston Valve in operation



2. Do not use valve "F" key for opening & closing the valve



3. Please do oiling of valve as shown in below figure with Molykote M30 oil or high temperature lubricating oil to ensure smooth operation of valve

### Lubrication Details (DN 65 - 250)

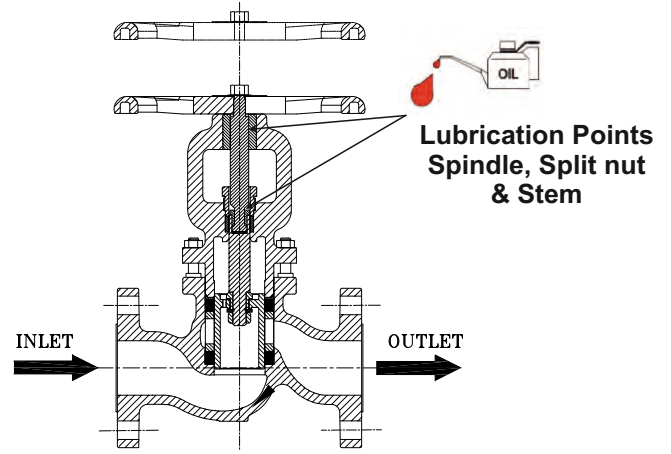

Operate the valve once or twice after lubrication.

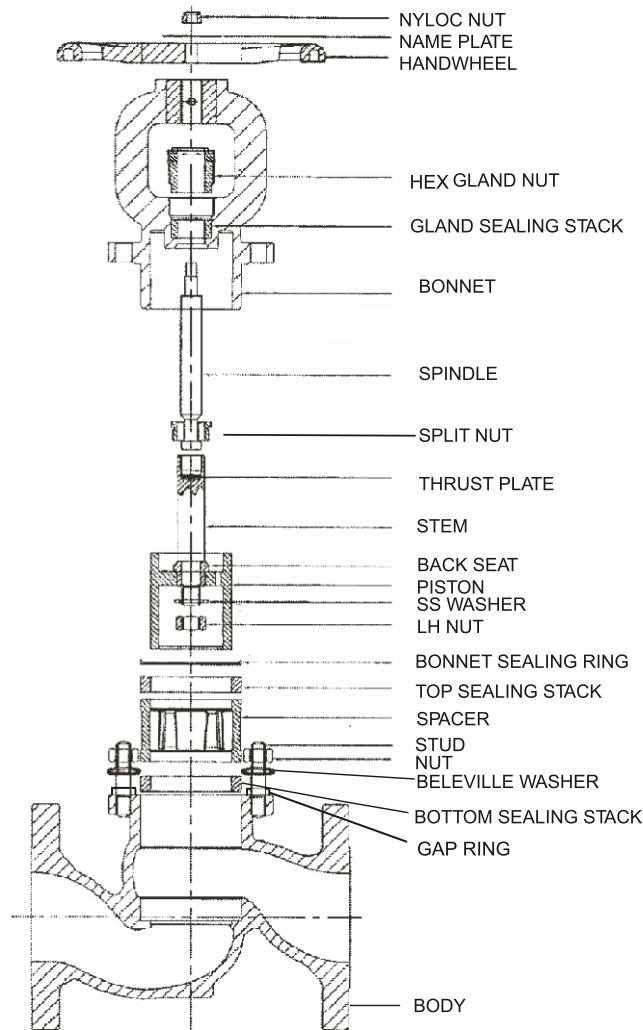

**DN 65-250  
EXPLODED VIEW**



www.forbesmarshall.com

Forbes Marshall Arca

Codel International

Krohne Marshall

Forbes Vyncke

Forbes Marshall Steam Systems

**A: Forbes Marshall Pvt. Ltd.**  
Opp. 106th Milestone, CTS 2220,  
Mumbai-Pune Road, Kasarwadi,  
Pune MH 411034 INDIA

**P:** +91(0)20-68138555

**F:** +91(0)20-68138402

**E:** ccmidc@forbesmarshall.com

© All rights reserved. Any reproduction or distribution in part or as a whole without written permission of Forbes Marshall Pvt Ltd, its associate companies or its subsidiaries ("FM Group") is prohibited.

Information, designs or specifications in this document are subject to change without notice. Responsibility for suitability, selection, installation, use, operation or maintenance of the product(s) rests solely with the purchaser and/or user. The contents of this document are presented for informational purposes only. FM Group disclaims liabilities or losses that may be incurred as a consequence of the use of this information.

**Forbes Marshall International Pte. Ltd.**

16A, Tuas Avenue 1,  
#05-21, JTC Space @Tuas  
Singapore - 639533

**P:** +65 6219 3890

**CIN No:** U28996PN1985PTC037806