

FMLDT31

Forbes Marshall Liquid Drain Trap

Description

The Forbes Marshall Liquid Drain Trap, FMLDT31, is an automatic liquid drain float trap for air systems. It has a cast iron body and cover with synthetic rubber valve head for positive closure.

Available Sizes and End Connections

DN 15, 20 and 25, Screwed BSPT/NPT/BSP ends

Limiting Conditions

PMA-Max. allowable pressure	13.0 bar (g)
TMA-Max. allowable temperature	220°C
Cold hydraulic test pressure	19.5 bar (g)
PMX-Max. differential pressure	13 bar (g)
Min. operating temperature	0°C

Operating Range

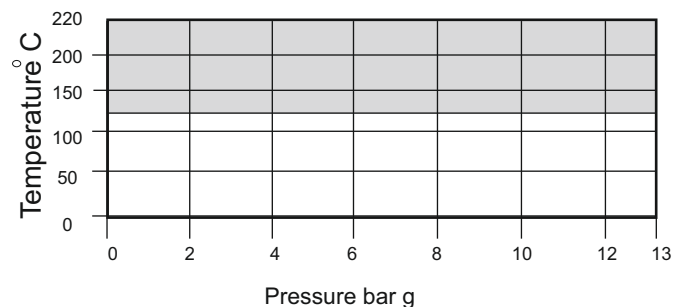

 The product must not be used in this region

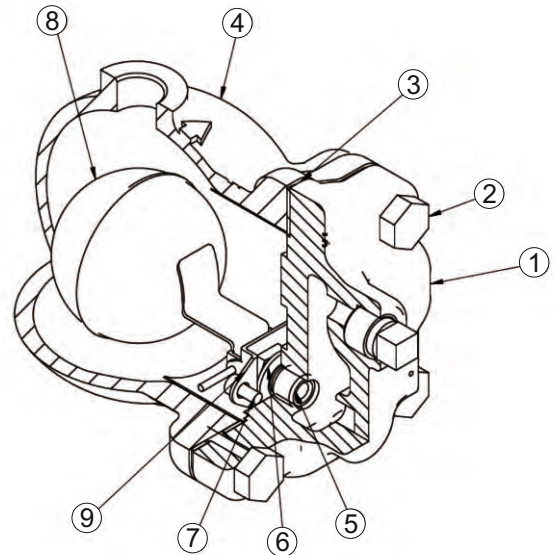

Materials

No.	Part	Material	Standard
1	Base	Cast iron	IS 210 FG 260
2	Cover Bolts	Carbon Steel	ASTMA193 B7
3	Cover Gasket	SS exfoliated graphite	
4	Cover	Cast iron	IS 210 FG 260
5	Valve Seat	Stainless steel	ASTMA 743 Gr.CA 40
6	Valve Seat Gasket	Stainless steel Type 410	SS410
7	Set Screws	Stainless steel Type 304	IS 1364
8	Ball Float & Lever	Stainless steel Type 304	ASTMA 240
9	Pivot Frame	Stainless Steel Type 304	ASTMA 240
10	Valve Head	Synthetic Rubber	Viton

Dimensions (approx.) in mm

Size	A	B	C	D	E	Weight(kg)
DN 15/20	130	109	72	152	120	2.9
DN25	141	109	72	160	135	4

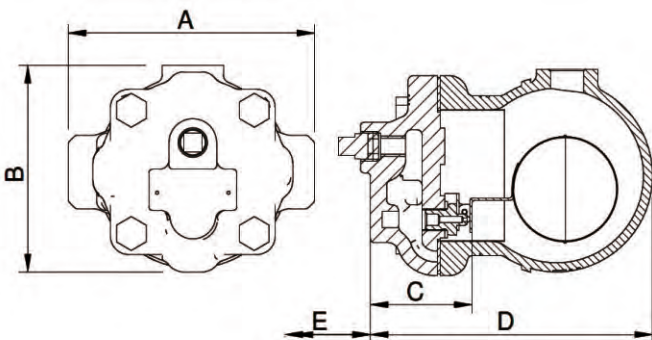

How to Order

Example : 1 No. DN 15 Forbes Marshall Liquid Drain Trap, FMLDT31 Screwed BSPT.

Installation

The trap should be fitted in a horizontal plane or vertical plane with inlet at the top so that the float mechanism is free to rise and fall in vertical plane. Point arrow on name plate downwards. The arrow on the casting indicates the flow direction. Refer user manual for further details.

How to Fit Main Valve Assembly

Isolate the trap, undo cover bolts, remove existing mechanism. Using a little jointing paste on the seat A thread and gasket B, fit the new valve seat to the body. Attach the pivot frame C to the body with assembly set screws F, but do not tighten. Fit the float arm to the pivot frame using the pin E and by moving the complete assembly center the valve head onto the seat orifice. Hold the assembly firmly in place and tighten up set screws to the recommended tightening torque. Check operation by raising and lowering the float several times making sure that the valve head is centering properly on the seat. Make sure all joint faces are clean; apply a thin coating of jointing paste to seat threads. Tighten cover bolts uniformly to the recommended tightening torque.

Maintenance

With suitable isolation, repairs can be carried out with the trap in the line. When reassembling it is advisable to make sure that all the joint faces are clean.

How to Order Spares

Always order spares by using the description given in the column headed 'Available Spares' in the user manual.

Capacity Chart

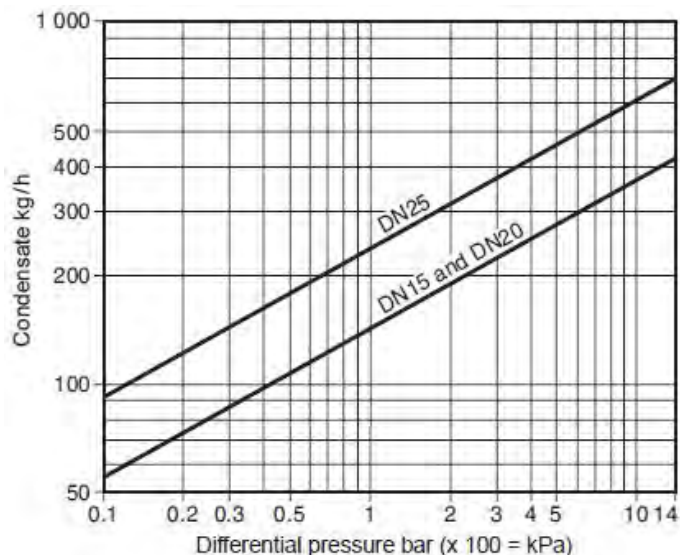

Recommended Tightening Torques

Part	Torque (Nm)
Main Valve seat	25-35
Cover Bolts	25-35

Spare Parts (Refer. Fig below)

Available Spares

Main Valve Assembly	A,B,C,D,E,F,G,T
Set of all Gaskets (packet of 3)	B,T
Float assembly	C

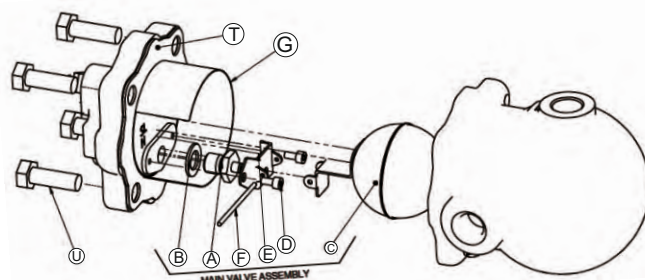

www.forbesmarshall.com

Forbes Marshall Arca

Codel International

Krohne Marshall

Forbes Vyncke

Forbes Marshall Steam Systems

A: Forbes Marshall Pvt. Ltd.
Opp. 106th Milestone, CTS 2220,
Mumbai-Pune Road, Kasarwadi,
Pune MH 411034 INDIA

P: +91(0)20-68138555

F: +91(0)20-68138402

E: ccmidc@forbesmarshall.com

© All rights reserved. Any reproduction or distribution in part or as a whole without written permission of Forbes Marshall Pvt Ltd, its associate companies or its subsidiaries ("FM Group") is prohibited.

Information, designs or specifications in this document are subject to change without notice. Responsibility for suitability, selection, installation, use, operation or maintenance of the product(s) rests solely with the purchaser and/or user. The contents of this document are presented for informational purposes only. FM Group disclaims liabilities or losses that may be incurred as a consequence of the use of this information.

Forbes Marshall International Pte. Ltd.

16A, Tuas Avenue 1,
#05-21, JTC Space @Tuas
Singapore - 639533

P: +65 6219 3890

CIN No: U28996PN1985PTC037806