

# FMSTR51/FMSTR52

## Forbes Marshall Cast Strainer

### Description

The Forbes Marshall Cast Strainer FMSTR51 / FMSTR52 is available in cast steel with stainless steel screen having 0.8 mm dia perforations as standard.

### Size and Pipe Connections

DN 15, 20, 25, 40 and 50  
Screwed BSPT, NPT, BSP(FMSTR51) and socket weld ends (FMSTR52). Available with IBR certificate.

### Limiting Conditions

Max Operating Pressure(bar g)

Size DN	Screwed	Socket Weld
15	55.0	55.0
20	50.0	50.0
25	55.0	55.0
40	55.0	55.0
50	55.0	55.0

Max operating temperature : 425°C  
Cold hydraulic test pressure : 1.5 times the operating pressure  
Min. working temperature : 0°C

### Operating Range

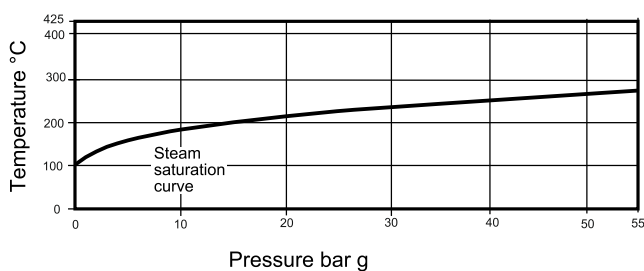

### Recommended Tightening Torques

Size (DN)	Torque (Nm) for cap
15	50-55
20	60-66
25	100-110
40	230-250
50	330-360

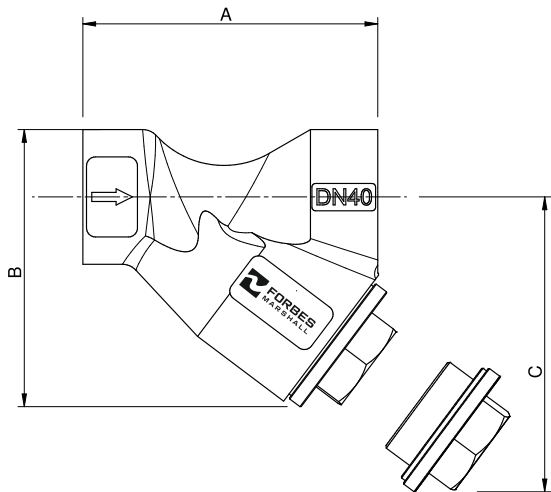

### Dimensions: (approx.) in mm

Size DN	A	B	C	D	Weight
15	73	60	100	37	2 kg
20	88	65	110	40	2 kg
25	105	80	135	50	3 kg
40	162	125	195	74	7 kg
50	188	145	235	87	9 kg

### Installation

The strainer should be installed in the direction of flow, as indicated on the body. On applications involving steam or gases the pocket should be in the horizontal plane. On liquid systems the pocket should point downwards. Suitable isolation valves must be installed to allow for safe maintenance and trap replacement.

### Maintenance note

Maintenance can be completed with the strainer in the pipeline.

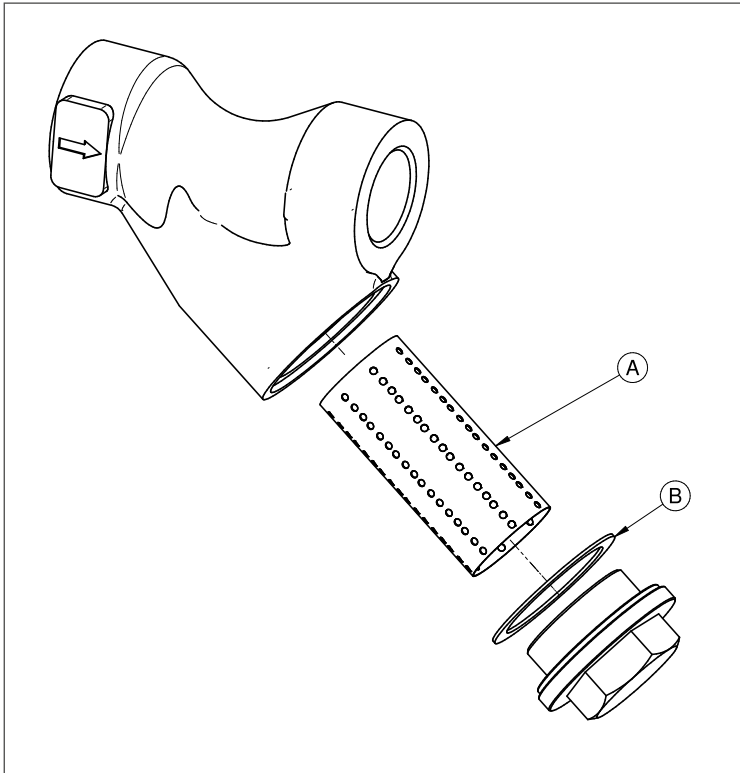
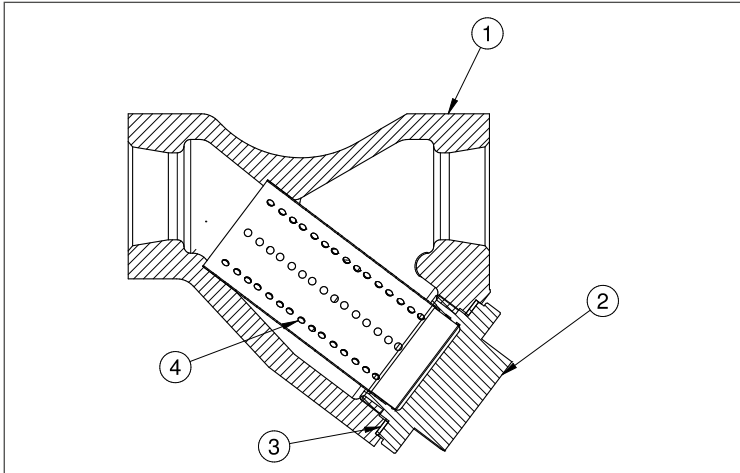
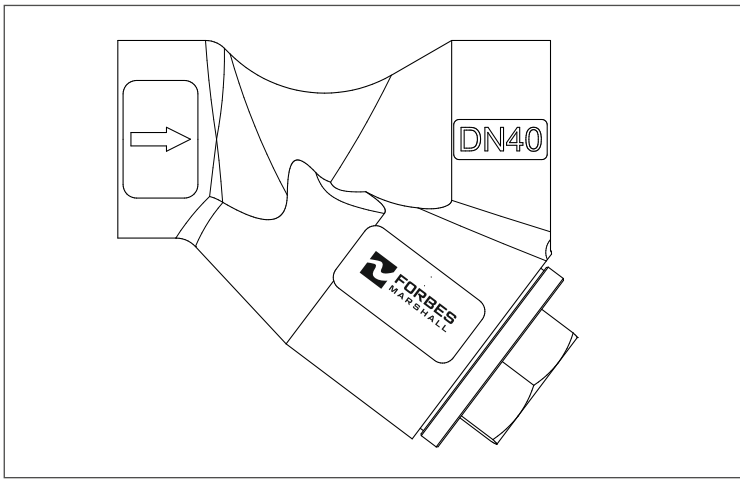

### Spare Parts

The spare parts available are shown in figure below.

### Available Spares

Parts strainer screen and gasket (A+B) are available as spares

### How to Order

**Example :** 1 no. DN40 Forbes Marshall Cast Strainer FMSTR51 / FMSTR52, screwed BSPT, IBR

### How to Order Spares

Always order spares by using the description given in the column headed Available Spares and stating the size and type of strainer and perforation or mesh required .

**Example:** 1No. strainer screen, stainless steel 304, 0.8mm perforation and gasket for DN40 Forbes Marshall Cast Strainer.

### Screen Details

Fitted as standard with a S.S 304 screen having perforation of 0.8mm Dia and other perforations are available to special order.

### Materials

No	Part	Material	Standard
1	Body	Cast steel	ASTM A216-WCB
2	Cap	Cast steel/Carbon Steel	15-20 NB ,ASTM A216 Gr. WCB 40-50 NB , ASTM A105
3	Gasket	SS Reinforced exfoliate graphite	
4	Screen	Stainless Steel	ASTM A240 SS 304



www.forbesmarshall.com

Forbes Marshall Arca

Codel International

Krohne Marshall

Forbes Vyncke

Forbes Marshall Steam Systems

**A: Forbes Marshall Pvt. Ltd.**  
Opp. 106th Milestone, CTS 2220,  
Mumbai-Pune Road, Kasarwadi,  
Pune MH 411034 INDIA  
**P:** +91(0)20-68138555  
**F:** +91(0)20-68138402

**E:** ccmidc@forbesmarshall.com

© All rights reserved. Any reproduction or distribution in part or as a whole without written permission of Forbes Marshall Pvt Ltd, its associate companies or its subsidiaries ("FM Group") is prohibited.

Information, designs or specifications in this document are subject to change without notice. Responsibility for suitability, selection, installation, use, operation or maintenance of the product(s) rests solely with the purchaser and/or user. The contents of this document are presented for informational purposes only. FM Group disclaims liabilities or losses that may be incurred as a consequence of the use of this information.

**Forbes Marshall International Pte. Ltd.**  
16A, Tuas Avenue 1,  
#05-21, JTC Space @Tuas  
Singapore - 639533  
**P:** +65 6219 3890

**CIN No:** U28996PN1985PTC037806