

FMTD64-U

Forbes Marshall Universal Thermodynamic Trap

Description

The Forbes Marshall Universal Thermodynamic Trap, FMTD64-U, is a stainless steel thermodynamic steam trap with integral strainer. All FMTD64-U traps are fitted by two screws to a pipeline connector to ensure the maintenance is quick and easily undertaken. Traps can be removed / replaced using a simple wrench with minimum system downtime.

Size and Pipe Connection

FMTD64-U can be fitted to a pipeline connector, FMPC, which has
 Inlet: DN 15 Socket welded ends / Screwed BSPT
 Outlet: DN 15 Socket welded ends / Butt welded ends
 FMPC51 / FMPC52 pipeline connector with optional drain valve available. Anti-Air Binding Disc also available (AABD) on request.

Limiting Conditions



Body design condition	PN 63
PMO-Max. operating pressure	42 bar g
TMO-Max. operating temperature	400 °C
Cold hydraulic test pressure	84 bar g
Min. operating temperature	0 °C

Note : Minimum pressure for satisfactory operation is 0.25 bar g
 PMOB- Max. Operating back pressure 80% of upstream pressure.

The model of the pipeline connector and connection selected will dictate the maximum operating pressure and temperature of the complete assembly. Consult the specified technical information sheet for more details.

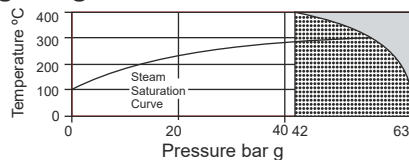
Operating Range



 The product must not be used in this region.
 The product should not be used in this region or beyond its operating range as damage may occur to the internals.

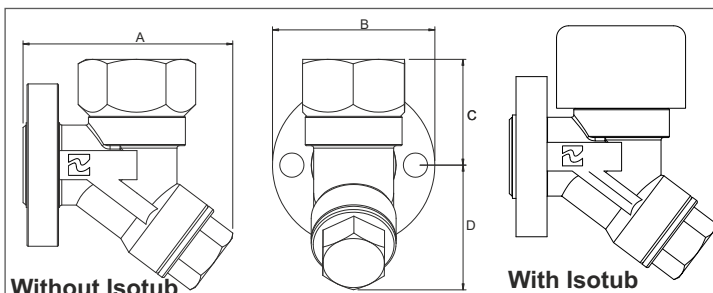

How to Order

The FMTD64-U trap is supplied in two parts-

1. The swivel pipeline connector
 - FMPC - standard
 - FMPC51/FMPC52 - with optional drain and depressurisation valve
2. FMTD64-U trap complete with inner and outer gasket and connector screws

Example

1. DN 15 FMPC with swivel pipeline connector with socket weld end connection.
2. FMTD64-U trap with gaskets and connector screws.

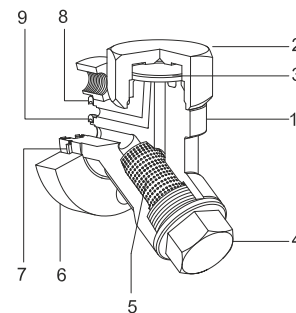

Material

Sr No	Part	Material	Standard
1	Body	Stainless Steel	ASTM A743 Gr. CA 40
2	Main bore CAP	Stainless Steel	BS3146 ANC 2
3	Disc	Stainless Steel	ASTM A 240 Ss420
4	Strainer CAP	Stainless Steel /Carbon Steel	BS3146 ANC 2
5	Screen	Stainless Steel	ASTM A240 SS 304
6	Flange	Carbon Steel	ASTM A105
7	Retaining Ring	Spring Steel	
8	Inner Gaskets	Spiral Wound Gasket	Stainless Steel
9	Outer Gaskets	Spiral Wound Gasket	Stainless Steel
10*	Bolts	Carbon Steel	ASTM A 193, B7
11	Isotub(optional)	Stainless Steel	ASTM A240 SS 304

* not shown in drawing

Note: Material specification mentioned in bracket are for reference only.

Dimensions (Approximate) in mm and weight

A	B	C	D	Weight (kg)
87	67	44	51	0.8

Capacity Chart

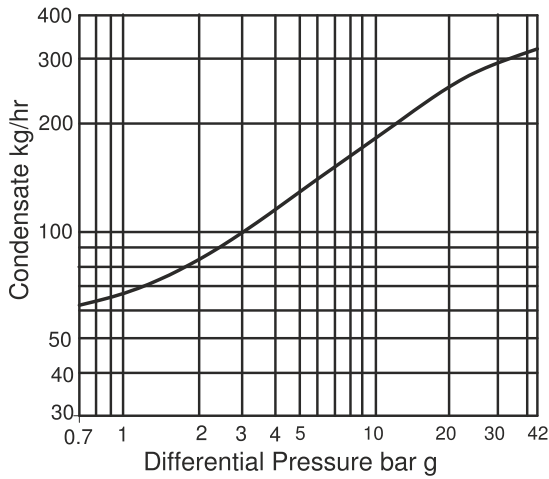

Installation

The pipeline connector can be installed in either horizontal or vertical pipe work. If the pipeline connector is to remain in the pipework for some time before the steam trap is coupled to it, the flange protector on the connector should be left in place. The mating flange on FMTD64-U trap is free to rotate 360°. Remove the protective plastic cover and ensure that both gaskets are clean and undamaged and that the transfer holes are clear. The steam trap is fitted with the cap above the center line of the trap. Place the FMTD64-U body against the connector gasket face and apply a small amount of anti-seize compound to the threads of the connector screws. Tighten screws finger tight and ensure that the trap is in horizontal position with the cap uppermost. Tighten the screws to the recommended torque. Full installation instructions are supplied with each unit.

Maintenance

Before undertaking any maintenance on the trap it must be isolated from both supply line and return line and any pressure allowed to safely normalize to atmosphere. The trap should then be allowed to cool to ambient temperature. Always ensure that the correct tools, safety procedures and protective equipment are used at all times.

To Replace the Disc

Remove the insulation cover if fitted and unscrew the cap using spanner. Do not use wrench of similar type which may cause distortion of the cap. If the disc and body seating faces are slightly worn they can be refaced by lapping individually on a flat surface such as surface plate. A figure of eight motions and a little grinding compound gives the best result.

If the wear is too great to be rectified by simple lapping, the seating surface on the body must be ground flat and then lapped and disc replaced by a new one. Total amount of metal removed in this way should not exceed 0.25 mm.

When reassembling, disc must be rectified be placed in position with the grooved side in contact with body seating face. Screw on cap; no gasket is required but suitable high temperature anti-seize compound should be applied to the threads.

To Clean / Replace Strainer

Unscrew strainer cap using spanner, withdraw screen and clean or if damaged replace with new one. To reassemble insert screen in to cap, then screw cap into place. Tighten cap to recommended torque.

If integral blow down valve is fitted it should be periodically blown down to remove debris collected in the screen. Blowdown screw must be tightened to the recommended torque. Ensure that adequate safety precautions are taken when opening the blow down valve to atmosphere. Hand protection is recommended.

To Replace Complete Trap Unit

Loosen the connector screw and remove the FMTD64-U trap unit. Clean the contact face on the connector. Position the new or reconditioned unit. Apply anti-seize compound to connector screw threads. Tighten screws finger tight and ensure trap is in horizontal position with top cap uppermost. Tighten the connector screws to the recommended torques.

Recommended Tightening Torques

Item	Torque (Nm)
Main bore Cap (2)	180-200
Strainer Cap (4)	170-190
Bolt M10 (10)	40-45

Spare Parts

The spares which are available are shown in heavy outline. Parts shown in a broken line are not available as spares.

Disc	Pack of 5	3
Connector screw & Gasket kit	Pack of 5	8,9,10
Strainer Screen	Pack of 5	5
Isotub kit	Pack of 1	11

How to Order Spares

Always order spare parts by using the description given in the Available Spares and state the size, Model No. And pressure rating of the trap.

Example: Strainer screen (FMTD64-U) pack of five.

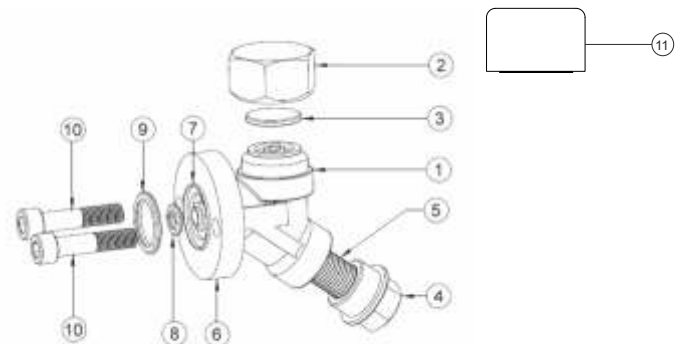

www.forbesmarshall.com

Forbes Marshall Arca

Codel International

Krohne Marshall

Forbes Vyncke

Forbes Marshall Steam Systems

A: Forbes Marshall Pvt. Ltd.
Opp. 106th Milestone, CTS 2220,
Mumbai-Pune Road, Kasarwadi,
Pune MH 411034 INDIA

P: +91(0)20-68138555

F: +91(0)20-68138402

E: ccmidc@forbesmarshall.com

© All rights reserved. Any reproduction or distribution in part or as a whole without written permission of Forbes Marshall Pvt Ltd, its associate companies or its subsidiaries ("FM Group") is prohibited.

Information, designs or specifications in this document are subject to change without notice. Responsibility for suitability, selection, installation, use, operation or maintenance of the product(s) rests solely with the purchaser and/or user. The contents of this document are presented for informational purposes only. FM Group disclaims liabilities or losses that may be incurred as a consequence of the use of this information.

Forbes Marshall International Pte. Ltd.
16A, Tuas Avenue 1,
#05-21, JTC Space @Tuas
Singapore - 639533

P: +65 6219 3890

CIN No: U28996PN1985PTC037806