

# CS40/42 Conductivity Sensors

The Model CS40 & CS42 sensors have been designed for a wide measurement range in difficult process conditions. It can be installed in submersion, insertion, or wet-tap configurations, and is good for most applications from high purity water to high chemical concentrations.

## Salient Features

Measures conductivity directly in process with high temperature option

O-ring seals used on all versions for high on-stream reliability

Optional wet-tap valve allows insertion and removal while line is under pressure

Wetted materials of construction are 316 stainless steel and teflon, depending on the range of temperature required. All possible leak paths through the sensor are double sealed with EPR O-rings for maximum on-stream reliability. The front O-rings protect the back ones from chemical attack, giving more than double the service life that can be expected from single sealed units.

Process connections are made via a bored through swage fitting with 3/4" NPT threads. This fitting can be screwed into a line, a tank, or the optional wet-tap valve assembly. It can be turned around and connected to a standpipe for use in a submersion configuration. Available probe constants range from 0.01 to 10.0 giving it the broadest range of application of any of our sensor models.

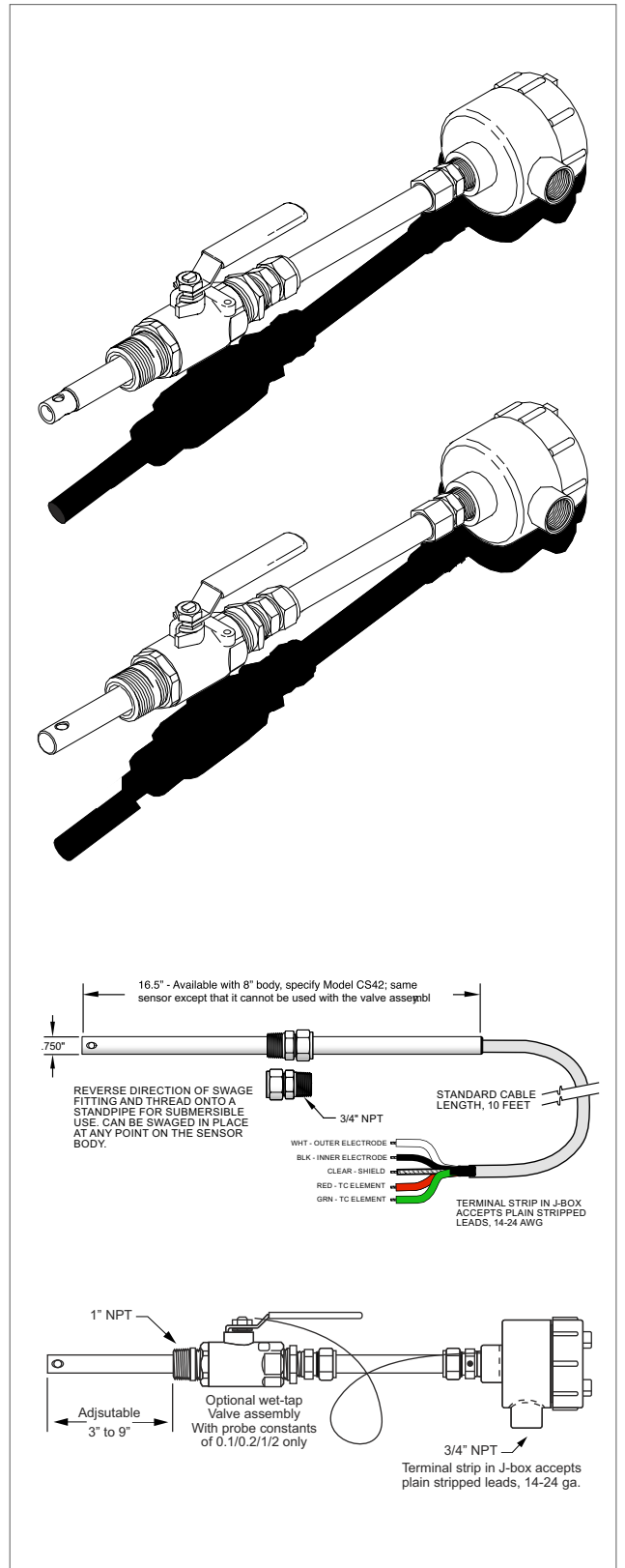

## Specifications

Maximum Pressure/ Temperature Ratings	
Standard sensor models - CS40 & CS42	100 PSIG at 150°C
High temperature sensor model CS40	250 PSIG at 205°C
Valve assembly for CS40	50 PSIG at all temperatures
Wetted Materials	
Electrodes	316 Stainless Steel
Insulator	PEEK
O-Rings	EPR
Optional Junction Box	Class 1, Group D, Div. 2, Weatherproof, Aluminum
Connections	
Process	3/4" MNPT /1" MNPT for valve
CS40 with valve assembly / right side	1" MNPT
Electrical	33' cable w/spade lugs optional j-box has 3/4" NPT hub and terminal strip

## Ordering Information

### Model CS40 with 3/4" NPT Connector

Part No.	Cell constant	Connection
CS40-001-HT-PT100-33'-3/4	0.01	3/4"NPT (M)
CS40-010-HT-PT100-33'-3/4	0.1	3/4"NPT (M)
CS40-100-HT-PT100-33'-3/4	1	3/4"NPT (M)
CS40-10-HT-PT100-33'-3/4	10	3/4"NPT (M)

### Model CS42 with 3/4" NPT Connector

Part No.	Cell constant	Connection
CS42-001-PT100-33'	0.01	3/4"NPT (M)
CS42-010-PT100-33'	0.1	3/4"NPT (M)
CS42-100-PT100-33'	1	3/4"NPT (M)
CS42-10-PT100-33'	10	3/4"NPT (M)

### Model CS40 with retractable SS ball valve assembly

Part No.	Cell constant	Connection
CS40-001-HT-SSV-33'	0.01	1"NPT (M)
CS40-010-HT-SSV-33'	0.1	1"NPT (M)
CS40-100-HT-SSV-33'	1	1"NPT (M)
CS40-10-HT-SSV-33'	10	1"NPT (M)

## Housing

Type	MOC	Part No.
Flow through chamber	SS316	FGC2013449
Flow through chamber	PP	FGC2011705

\*Above models comes with inbuilt 10 M Cable. Different cable lengths are also available.  
Sensor model CS42 does not have ball valve assembly option.



Forbes Marshall  
Krohne Marshall  
Forbes Marshall Arca  
Codel International  
Forbes Solar  
Forbes Vyncke  
Forbes Marshall Steam Systems

A-34/35, MIDC H Block Pimpri, Pune - 411 018. INDIA.  
Tel : 91(0)20-27442020, 68131100  
Fax : 91(0)20-27442040

Email : pasales@forbesmarshall.com, ccmidc@forbesmarshall.com  
www.forbesmarshall.com

CIN No.: U28996PN1985PTC037806

© All rights reserved. Any reproduction or distribution in part or as a whole without written permission of Forbes Marshall Pvt Ltd, its associate companies or its subsidiaries ("FM Group") is prohibited.  
Information, designs or specifications in this document are subject to change without notice. Responsibility for suitability, selection, installation, use, operation or maintenance of the product(s) rests solely with the purchaser and/or user. The contents of this document are presented for informational purposes only. FM Group disclaims liabilities or losses that may be incurred as a consequence of the use of this information.