

User Manual – Solids



effiMAX

Energy Conservation | Environment | Process Efficiency

Cloud Based effiMAX

User's Manual

This user manual corresponds to Cloud Based effiMAX product which is meant for monitoring & maintaining the peak Efficiency of the Boiler.

If you experience difficulty with the installation or operation of this system, please contact our Customer service representative.

Developed and Marketed by:

Forbes Marshall Pvt. Ltd.

V 1.0

Table of Contents

Table of Contents	1
Safety Information	4
1 Introduction	5
1.1 Cloud Based EffiMAX Concept	5
1.2 Features	12
1.3 Specifications	16
1.4 Product Dimension Details	19
2 Installation	20
2.1 Unpacking and Inspection	20
2.2 Packing List	20
2.3 Tools required for installation	21
2.4 Location and Mounting	21
2.5 Installing the Sub-Systems	22
2.6 Cable and Wiring of Sub-System and Analyzer	27
2.7 Connection Details	30
2.8 Commissioning the Product	37
3 Eversense installation	40
4 Operating EffiMAX	42
4.1 Operating the System from Plant Level	42
4.2 Operational Guidelines	50
5 Blowdown System	90
5.1 Introduction	90
5.2 Operating Principle	90
5.3 Assembly of the System	93
5.4 Commissioning the System	97
5.5 Troubleshooting	99
6 Temperature Transmitter	100
6.1 Introduction	100
7 Maintenance Schedule	101
7.1 TDS system	101
7.2 Oxypro	102
7.3 Temperature Transmitter	102

Table of Contents

8	Spares List	104
9	Do's And Don'ts	105
10	Log Report	106
11	Installation Drawings	108

List of Figures

Fig No.	Description
Fig. 1	effiMAX Monitoring System
Fig. 2	effiMAX Control System
Fig. 3	System Architecture
Fig. 4	Product Dimension Details
Fig. 5	Hardware Architecture
Fig. 6	Typical Operation 1
Fig. 7	Typical Operation 2
Fig. 8	BBCS Assembly details
Fig. 9	Steam Flow Meter Installation diagram
Fig. 10	Steam Temp. Transmitter Installation diagram
Fig. 11	Feed water Temp. Transmitter Installation diagram
Fig. 12	Stack Temp. Transmitter Installation diagram
Fig. 13	Stack Oxygen Sensor Installation diagram
Fig. 14	TDS Sensor Installation diagram
Fig. 15	Steam Pressure Transmitter Installation diagram



Safety Information

To ensure that your product is safe and without risk to health, the following points must be noted:

1. The relevant sections of these instructions must be read before proceeding.
2. The **Forbes Marshall effiMAX System** should be installed and operated only in manner specified in this User Manual.
3. Installation, Operation, Maintenance and Servicing must only be carried out by suitable trained personnel and in accordance with the information given. Any deviation from these instructions will transfer the complete liability to the user.
4. **To prevent the system from Electrical noise / transients on Earth Line, please connect separate Instrument Earth to the Earth terminal screw provided on the Panel / Enclosure.**
5. Warning labels on containers and packages must be observed.
6. Safety precautions must be taken to avoid the possibility of an accident occurring when operating in conditions of high temperature.
7. Before making any wiring changes, please make sure the Power supply to the unit is turned off.
8. The Oxygen probe is operated at the temperature level of **800°C**. Please **DO NOT** touch the oxygen probe surface when in operation.
9. **For seamless operation of the product, It is recommended to have UPS supply to the system.**

SECTION 1: INTRODUCTION

1.1 Cloud Based effiMAX Concept

Cloud Based effiMAX, the latest offering from the effiMAX range of on-line boiler efficiency analyzers, provides the complete solution for monitoring, maintaining your boiler to the optimum efficiency and controlling ID fan, FD fan, Feeders and Drum level. This sophisticated yet simple to use analyzer operates on-line and continuously monitors your boiler at every instant of its operation.

effiMAX (Solids) calculates the efficiency of the Solid fired boiler in general accordance with the BS-845 standard based on indirect / direct efficiency computation depending on the variant and computes individually the total amount of losses in your boiler. These losses include Stack loss, Enthalpy loss, Radiation loss and Blowdown loss. The data generated by the system can then be used to fine-tune the system to generate more steam with lesser quantities of fuel.

As per the variant, the on-line parameter screen displays : Oxygen in the stack, Stack temperature, Steam flow (density compensated), fuel flow, Steam temperature, Feed-water temperature, Ambient temperature and TDS of boiler water, which forms the basis of calculating the efficiency and help you to check the operating conditions of your boiler & maintain the boiler at peak efficiency.

Introduction

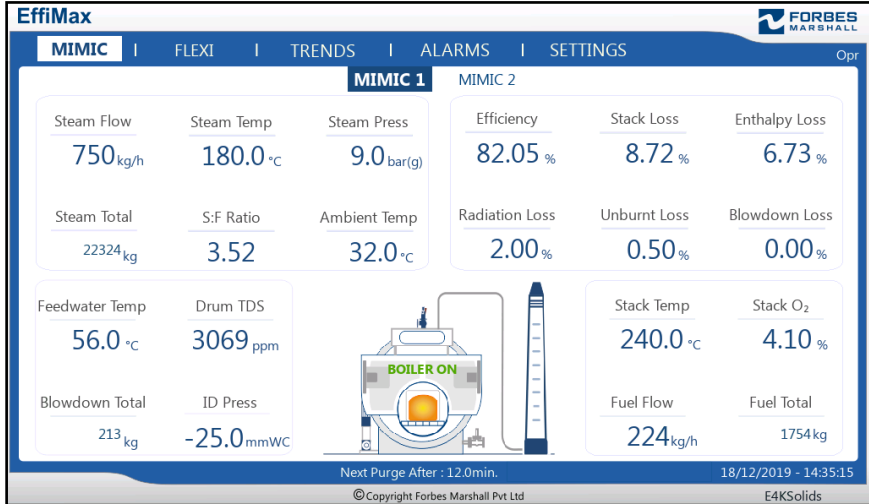

Fig. 1- effiMAX Monitoring System

The effiMAX now comes with the user friendly 10" touch screen display. The first screen displays the graphical representation of the boiler and all online parameter values. The Touch screen Interface of *effiMAX* presents data like the input parameters and the losses on user friendly screens with real-time and historical trends. Boiler performance can be improved from the continuous monitoring of all the parameters.

The navigation to different screens like Trends, Alarms, Settings, etc. can be easily done by touching the specific buttons on the display.

This display also provides pop up keypad for easy data entry and settings, eliminating the use of any fixed keys.



Fig. 2- effiMAX Control System

The Touch screen Interface of *effiMAX* presents control loop data on user friendly screens with historical trends. Boiler performance can be improved from the continuous monitoring of all the parameters. All control loops live status helps in monitoring complete boiler control performance on single page and easy to fine tune.

Historical trends for can be viewed simply by touching the Trend icon button provided on respective control tile.

Introduction

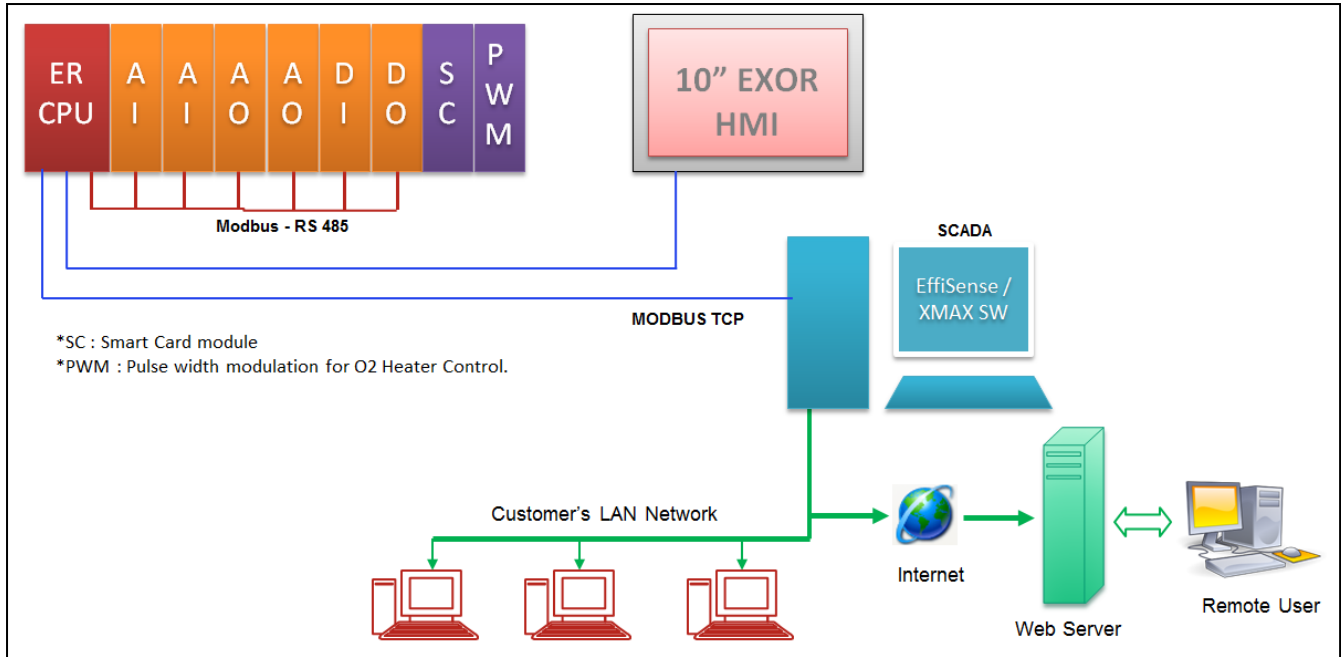

Fig.3 -System Architecture

The *EffiMAX* system is made up of the following components:

1. Panel unit :

The Panel unit of *EffiMax* displays online data of all the input parameters and the losses on user friendly 10" touch screen with real-time and historical trends. This unit is connected to all the field mounted sensors of the system and acquires on-line data. The values transmitted by the field sensors are converted to a standard format & then and given to the HMI which displays them on its relevant screens. These values are then used to compute the efficiency of the boiler.

2. EffiSense Unit :

EffiSense is a data logging & remote monitoring software system. It receives data from EffiMax Panel unit. It logs the required data and generates graphical and text reports for the boiler operator and the management, to analyze boiler performance at a glance. The data from EffiSense can be viewed remotely either in the Local network or over the Internet through a Global Static IP.

3. Oxygen Measurement Probe :

The oxygen measurement probe is mounted on the stack of the boiler and it measures the % O₂ in the flue gas. This is an important parameter for efficiency calculations. The % O₂ in the flue gas indicates the operating excess air level of the boiler and hence the health of combustion.

4. Stack temperature transmitter:

The stack temperature transmitter is mounted on the stack and is used to measure the flue gas temperature. This is used for calculation of combustion losses in the boiler along with oxygen content of the flue gas, ambient temperature, calorific & stoichiometric values of the fuel used.

5. Steam flow meter:

The Vortex Steam flow meter is mounted on the main header line of steam and is used to measure the volumetric flow-rate. The volumetric flow-rate is converted into mass flow-rate in the Display unit. Steam flow of a boiler is the most important parameter to be monitored, as it indicates the total useful output from a boiler.

If instead of Vortex, Orifice flow meter is used for steam flow measurement then differential pressure, steam pressure and steam temperature will be used to calculate mass flow-rate in the Display unit.

6. Steam temperature transmitter:

The steam temperature transmitter used for measuring temperature of the steam is mounted just after the steam flow meter on the main boiler header. The steam temperature is used for on-line density compensation of the volumetric flow measured by the steam flow meter.

7. Steam Pressure transmitter:

The steam pressure transmitter used for measuring pressure of the steam is mounted on the steam line with syphon as close to the steam drum as possible. This may be used for on-line density compensation for the volumetric flow measured by the steam flow meter.

8. Blowdown TDS Sensor and Valve:

The blowdown sensor and the blowdown valve are mounted on the piping of the blowdown line. The sensor measures the Total Dissolved Solids (TDS) of the boiler drum water intermittently when the blowdown valve is opened. The EffiMAX unit then compares this value with the user fed set point and controls the TDS level.

If standalone TDS sensor is installed, then the sensor will measure the Total Dissolved solids in the Boiler water & will display it on the screen.

9. Feed-water temperature transmitter:

The feed-water temperature transmitter is mounted on the feed-water line and measures the feed-water temperature. This value is used for calculating Direct Efficiency of the Boiler.

10. Ambient Temperature Transmitter:

This transmitter is mounted near the EffiMAX unit and it measures the ambient air temperature. This value is used for the Stack and Enthalpy loss calculation.

11. Solid Fuel Flow Metering (Using V to I converter):

The solid fuel is metered from the number of rotations made by the feeder of your boiler. The feedback from the feeder is taken to the Signal conditioning unit using a V to I converter. A calibration chart entered in the Display unit needs to be filled for amount of flow rate (kg/h) at various RPM. This chart then helps us in analyzing the amount of fuel consumed by the boiler.

12. ID Pressure Transmitter :

ID Pressure transmitter is used for measurement of Induced draft pressure which is maintained between the min & max set point by the Oxygen trim control logic. The value transmitted by this sensor act as an interlock in the trim control logic. If ID pressure crosses its min or max limits then the trim control logic is governed by ID pressure instead of stack oxygen until the ID pressure is back in the specified limits.

Introduction

1.2 Features of EffiMAX

Measured Parameters:

	EffiMAX 1000	EffiMAX 2000	EffiMAX 3000	EffiMAX 4000
Steam Flow (kg/h)	√	√	√	√
Fuel Flow (kg/hr)	√	-	√	√
Stack Oxygen (%)	-	√	√	√
Steam Temperature (°C)	√	√	√	√
Stack Temperature (°C)	-	√	√	√
Steam Pressure (kg/cm2(g))	√	√	√	√
Feedwater Temperature (°C)	√	√	√	√
Ambient Temperature (°C)	-	√	√	√
Drum TDS (ppm)	Optional	√	√	√
ID Pressure (mmWC)	-	-	-	√
Drum Level (%)	-	√	√	√
ID O/P (%)	-	-	-	√
FD O/P (%)	-	-	-	√
Feeder O/P (%)	-	-	-	√
Drum Level O/P (%)	-	-	-	√

Calculated Parameters:

	EffiMAX 1000	EffiMAX 2000	EffiMAX 3000	EffiMAX 4000
Boiler Efficiency (Direct) (%)	√	-	√	√
Boiler Efficiency (Indirect) (%)	-	√	√	√
Stack Loss (%)	-	√	√	√
Enthalpy Loss (%)	-	√	√	√
Blowdown Loss (%)	-	√	√	√

Radiation Loss (%)	-	√	√	√
Unburnt Loss (%)	-	√	√	√
Steam to Fuel Ratio (Direct)	√	-	√	√
Steam to Fuel Ratio (Indirect)	-	√	-	-
Steam Totalization (kg)	√	√	√	√
Fuel Totalization (kg)	√	-	√	√
Blowdown Totalization (kg)	√	√	√	√
Boiler On-Off Totalization	√	√	√	√
Boiler Blowdown control	√	√	√	√

effiMAX for Superheated boilers:

effiMAX can be used to display Superheated Steam Temperature and Pressure. Due to high temperature and pressure, instead of HTCS sensor and corresponding assembly, medium pressure BBCS is used for TDS measurement. Here, water sample is taken and cooled to ambient temperature to measure the TDS. Then corresponding 4-20mA output is given to effiMAX which displays the TDS on continuous basis. If the TDS is higher than the set point mentioned in the BBCS, blowdown control valve is opened which sends a digital signal to EffiMAX to display the total blowdown occurred.

effiMAX for Orifice meters used to measure Steam flow:

On site, if orifice meters are present to measure steam flow, it can be connected to effiMAX. Along with Steam Pressure and Temperature readings and orifice plate related parameters, effiMAX displays the steam parameters. Following parameters are to be entered on Boiler Data page of effiMAX for steam flow calculation:

GA Gain input A1, GB Gain input A2, GC Gain input A3, GO Gain Output C, BA Bias input A1, BB Bias input A2, BC Bias input A3, BO Bias Output C, Max. Delta P, Max. Steam Pressure, Max. Steam Temperature.

Introduction

Flexi Parameters:

In addition to the standard effiMAX parameters, if more parameters are to be displayed like Water flow total, Furnace Pressure etc., the facility is available in effiMAX. Standard Analog input (4-20mA) signal is required for the same. Maximum 12 no's of flexi inputs can be configured but according to the variant's number of AI cards need to be installed in panel.

Configuration of these parameters is done from Product Page in the Settings tab. The parameter name and unit are to be assigned. Depending on the averaging or totalization requirement, select 'Avg.' or 'Total' option.

The screenshot displays the 'EffiMax' software interface, specifically the 'SETTINGS' tab. The interface is divided into several sections: 'MIMIC', 'FLEXI', 'TRENDS', 'ALARMS', and 'SETTINGS'. The 'FLEXI' section is active, showing a table for configuring Flexi Parameters. The table has columns for 'System', 'Feeder', 'Product', and 'Alarm Limits'. The 'Product' column is expanded to show a list of parameters with their respective configurations.

System	Feeder	Product	Alarm Limits
A/I 1	Steam Flow 1	Average / Total: ITTL, Unit: kg/h, Enable: <input checked="" type="checkbox"/>	Analog Input: Steam Total 1, Unit: kg, Enable: <input checked="" type="checkbox"/>
A/I 2	SPM	Average / Total: AVG, Unit: mg/Nm3, Enable: <input checked="" type="checkbox"/>	
A/I 3	Feedwater Hardness	Average / Total: AVG, Unit: ppm, Enable: <input checked="" type="checkbox"/>	
A/I 4	Feedwater Flow	Average / Total: ITTL, Unit: kg/h, Enable: <input checked="" type="checkbox"/>	Feedwater Total, Unit: kg, Enable: <input checked="" type="checkbox"/>

The interface also shows a status bar at the bottom with the date and time '31/12/2019 - 13:43:29', a copyright notice '© Copyright Forbes Marshall Pvt Ltd', and the identifier 'E4KSolids'.

Range of the parameters is to be entered from Range Page -> Flexi (Under drop down).

EffiMax FORBES MARSHALL

MIMIC | FLEXI | TRENDS | ALARMS | **SETTINGS** | Opr

O₂ Cal | PID | Boiler Data | Fuel Type | Blowdown | Limits | **Range**

System | Feeder | Product | Alarm Limits | Flexi

Flexi Parameter	Min. Count	Max. Count	Min. Range	Max. Range	Actual Count	Actual Value
Steam Flow 1	10486	52428	2000	10000	0	2000 kg/h
SPM	10486	52428	30	999	0	30 mg/Nm ³
Feedwater Hardness	10486	52428	150	6000	0	150 ppm
Feedwater Flow	10486	52428	2200	15000	0	2200 kg/h

31/12/2019 - 13:43:56
© Copyright Forbes Marshall Pvt Ltd E4KSolids

Thus, these flexi parameters are displayed on Flexi page.

EffiMax FORBES MARSHALL

MIMIC | **FLEXI** | TRENDS | ALARMS | SETTINGS | Opr

Flexi Parameter	Value	Unit	Total Reset
Steam Flow 1	2000.0	kg/h	
Steam Total 1	4272	kg	<input type="checkbox"/>
Feedwater Hardness	150.0	ppm	
Feedwater Flow	2200.0	kg/h	
Feedwater Total	4684	kg	<input type="checkbox"/>

31/12/2019 - 13:43:02
© Copyright Forbes Marshall Pvt Ltd E4KSolids

Introduction

1.3 Specifications

ANALYZER UNIT SPECIFICATIONS

EffiMAX Panel unit :

Mechanical enclosure:	Wall-mount / Floor Mount unit
Electrical supply:	230V AC, 3A, 50Hz, UPS Supply
Operating Temp:	0 – 50 °C

Parameter Ranges :

Efficiency Indication:	0 - 100 %
Stack Loss:	0 - 100 %
Radiation Loss:	0 - 100 %
Enthalpy loss:	0 - 100 %
Blowdown loss:	0 - 100 %
Blowdown Totalization:	0 - 1000000000 kg
Ambient air temperature Indication:	0 - 100 °C
Feed-water temperature Indication:	0 - 200 °C
Steam temperature Indication:	0 - 300 °C
Stack temperature Indication:	0 - 400 °C
Oxygen Indication:	0.0 - 20.9%
ID Output	0 – 100%
FD Output	0 – 100%
Feeder Output	0 – 100%
Drum Level Control Output (Optional)	0 – 100%
Steam flow indication:	As per the programmed range (kg/h)
Steam flow Totalization:	0 - 1000000000 kg
Fuel flow Totalization:	0 - 1000000000 kg
S:F ratio:	0 - 20
TDS Set Point range:	0 - 6000 ppm.

SUB SYSTEM SPECIFICATIONS

TDS Measurement

Sensor:	HTCS Sensor
Sensor chamber:	ASTM A-182 F304 body
Max boiler pressure:	31 bar g

BBCS (Boiler Blowdown Control System)

Air pressure required:	3 to 6 bar g
Blowdown valve:	SS ball valve with pneumatic actuator and solenoid in the air line
Solenoid voltage:	230 V AC, 50 Hz

Steam Flow Meter

Measuring error:	$\pm 1.0\%$ of measured value ($Re \geq 20000$) $\pm 2.0\%$ of measured value ($10000 < Re < 20000$) Pressure and temperature compensation: $\pm 1.5\%$ of measured value ($Re \geq 20000$); $\pm 2.5\%$ of measured value ($10000 < Re < 20000$)
Repeatability:	+/- 0.1% of measured value

Stack Temperature Transmitter

Temperature Sensor:	2-wire loop powered, integral head mounted transmitters
Range:	0 to 400 °C
Accuracy:	1 % of measured value
Process connection:	½" BSP (male), Length – 18" below the head

Steam Temperature Transmitter

Temperature Sensor:	2-wire loop powered, integral head mounted transmitters
Range:	0 to 300 °C

Introduction

Accuracy:	1% of measured value
Process connection:	½" BSP (male), Length – 12" below the head

Feed-Water Temperature Transmitter

Temperature Sensor:	2-wire loop powered, integral head mounted transmitters
Range:	0 to 200 °C
Accuracy:	1% of measured value
Process connection:	½" BSP (male), Length – 6" below the head

Ambient Air Temperature Transmitter

Temperature Sensor:	2-wire loop powered, integral head mounted transmitters
Range:	0 to 100 °C
Accuracy:	1% of measured value
Process connection:	½" BSP (male), Length – 6" below the head

V to I Converter for Solid Fuel Metering :

Power Supply:	230V AC, 50Hz Supply
Type of converter (Based on I/P signal from Drive)	(i) 0 – 24 VAC (ii) 0 – 230 VAC (iii) 0 – 10 VDC
Output Signal	4-20 mA

ID Pressure Transmitter :

Range :	(i) -50 to + 50 mmWC (ii) -25 to +25 mmWC
Output Signal	4-20 mA

Auto-Manual Station for Controlling :

Power Supply:	230V AC, 50Hz Supply
Output Signal	4-20 mA

1.4 Product Dimension Details



Fig.4 - Product Dimension Details

SECTION 2: INSTALLATION

2.1 Unpacking and Inspection



- ❖ Inspect the shipping carton for any damages. If there are no visual damages open the carton.

- ❖ Check all the items as per packing list. If any of the items are missing, please inform the same to **Forbes Marshall** local representative.



- ❖ If it is damaged then, inform the damage to the transporter for further action. It is recommended to take photograph in case of any insurance claims.

2.2 Packing List

	Qty.	EffiMAX 1000	EffiMAX 2000	EffiMAX 3000	EffiMAX 4000
1. Panel Unit	1 No.	√	√	√	√
2. EffiSense Monitoring Unit	1 No.	√	√	√	√
3. Temperature Transmitter (0-100 °C)	1 No.	-	√	√	√
4. Temperature Transmitter (0-200 °C)	1 No.	√	√	√	√
5. Temperature Transmitter (0-300 °C)	1 No.	√	√	√	√

6. Temperature Transmitter (0-400 °C)	1 No.	-	√	√	√
7. O2 Sensor Probe	1 No.	-	√	√	√
8. BBCS Sensor (TDS)	1 No.	√	√	√	√
9. Steam Flow Meter	1 No.	√	√	√	√

2.3 Tools required for installation



1. 1/4-inch flathead screwdriver (for the Analyzer unit).
2. 1/8-inch flathead screwdriver (for the Analyzer unit).
3. ½-inch BSW box spanner with torque wrench (for installation).
4. Size 8 and 10 adjustable spanner wrench (for steam flow meter, temperature transmitters and the Blowdown system).

2.4 Location and Mounting



- ❖ For best results install the unit in area where temperature is ambient & vibrations are less.
- ❖ Install the panel, such that on left or right side there is place for cable entry.
- ❖ Fix the panel to the floor by using fasteners through the holes provided at the bottom of the panel.

Installation

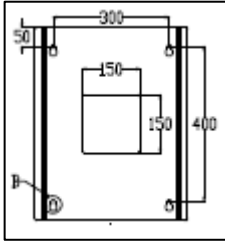

Mounting Plate for Enclosure:

Ensure that mounting bracket is held properly on the wall.

2.5 Installing the Sub-System



To prevent the system from Electrical noise / transients on Earth Line, please connect separate Instrument Earth to the Earth terminal screw provided on the Signal Conditioning Enclosure.

Please don't short the transmitter wires. It may cause analog input failure!

2.5.1 Installing Steam Flow Meter:

- The Steam flow meter should be installed with straight pipe of (20 x size of meter) at upstream & (5 x size of meter) at downstream of the meter.
- Please refer 'Steam flow Meter Installation diagram' in Section 11 & 'installation video' for Installation details.

2.5.2 Installing Stack Temperature Transmitter:

- Screw the adapter of Stack temperature transmitter into the ½" BSP socket - welded for the same on the stack. Ensure a leak tight connection. Use Teflon tape if required.
- Pass temperature transmitter through the adapter and tighten it.
- Please refer 'Stack Temperature Transmitter Installation diagram' in Section 11 & 'installation video' for Installation details

2.5.3 Installing Ambient Air Temperature Transmitter:

- Screw the adapter of ambient temperature transmitter into the ½” BSP socket welded for the same on the combustion air duct or in the Ambient mounting bracket, depending on where the sensor needs to be installed. Ensure a leak tight connection when mounted on duct. Use Teflon tape if required.
- Pass temperature transmitter through the adapter and tighten it.
- Make sure the transmitter is protected from direct sunlight and water.

2.5.4 Installing Steam temperature transmitter:

- Install this transmitter only at the downstream of the Steam Flow meter and not before it.
- Screw the thermowell into the ½” socket welded for the same on the steam line.
- Ensure that the connection is leak tight. Use Teflon tape for sealing if required.
- Pour a small quantity of transformer oil, sufficient enough to fill the gap between the inner wall of the thermowell and the outer wall of the temperature transmitter, into the thermowell.
- Screw the temperature transmitter into thermowell.
- Please refer ‘Steam Temperature Transmitter Installation diagram’ in Section 11 & ‘installation video’ for Installation details.

2.5.5 Installing Steam pressure transmitter:

- Tapping should be provided on the steam line for connecting steam pressure transmitter.
- Connect the syphon to protect the transmitter from extreme temperatures. Water barrier formed in the syphon protects the transmitter from impurities. Size and material of the syphon should be suitable as per the pressure rating.

Installation

- Use least no. of fittings to avoid leakage problems and install as close to the steam drum as possible.
- Install the transmitter on the provided mounting bracket.
- Protect pressure transmitter from direct contact of water and other liquids.

2.5.6 Installing Feed-water temperature transmitter:

- Screw the thermowell into the ½” socket welded for the same on the feed-water line.
- Ensure that the connection is leak tight. Use Teflon tape for sealing if required.
- Pour a small quantity of transformer oil, sufficient enough to fill the gap between the inner wall of the thermowell and the outer wall of the temperature transmitter, into the thermowell.
- Screw the temperature transmitter into thermowell.
- Please refer ‘Feed water Temperature Transmitter Installation diagram’ in Section 11 & ‘installation video’ for Installation details.

2.5.7 Installing Stack Oxygen Probe:

- The dimensions for the hole in the flue gas duct and the mounting of the adapter plate (mating flange) are shown in the dimensional drawing below. The mating flange is to be fitted by the customer and when mounting please ensure an air tight seal.
- The part of the protection tube projecting from the duct wall must be insulated or heated, if necessary, to prevent its temperature from dropping below the dew point.
- Electrical heaters are available from FORBES MARSHALL as accessories. The bolts of the probe flange must remain accessible.
- The special cables for electronic systems must be left long enough (coiled up) so that the probe can be drawn out of the protection tube without disconnecting it.

2.5.8 Installing a Blowdown System:

Blowdown system can be installed either for monitoring & controlling the Boiler water TDS (BBCS) or for only monitoring the TDS value (standalone TDS Sensor).

BBCS Installation:

The main Blowdown valve is fitted at the bottom of the boiler for draining and removing any sludge accumulation from the bottom of the boiler. It should be fitted into the space left in the Boiler Blowdown Control System (in which a spool piece is supplied) and should be manually opened for a few seconds on a daily basis. The Boiler Blowdown Control System limits the concentration of dissolved and suspended solids in the boiler water. Therefore, the take-off point need not be from the bottom of the boiler. Indeed, using a side connection (if one exists) instead reduces the chance of scale entering the Blowdown valve. In case the system has been supplied as separate components, follow the instructions in Section 4 of this User Manual for assembling the system.



The EffiMAX Analyzer unit gives a 230/115Vac Signal for the solenoid valve to operate. This connection should be made when the unit is switched off.

Standalone TDS sensor installation:

The TDS sensor measures the concentration of dissolved and suspended solids in the boiler water. This sensor is installed in a sensor housing chamber which is then fitted on the Blowdown line. Please refer section 4 for detailed installation instructions.



The plug tail supplied is 1.25 m long. For longer distances use a junction box and screened cable. The screen should not be connected to earth anywhere along its length.

2.5.9 Installing ID Pressure Transmitter:

- Before installing the ID Pressure Transmitter make sure that:
 - Induced draft tapping is drilled one meter above the bed.
 - Metallic tube is inserted in a half inch BSP socket connected to the tapping.
 - Ferrule and nut is used for the connection of metallic tube.
 - The tube has minimum bends.
 - The connection from the tapping of the tube is leak tight.
- At mounting location of ID pressure transmitter, make sure that:
 - Location is away from the hot boiler surface.
 - A stand with mounting plate is provided to mount the Furnace pressure transmitter.
- Refer the Pressure transmitter user manual for size and location of bolts for mounting purpose.
- Connect other end of the metallic tube to the negative port of the Differential pressure cell.
- Keep the positive port open to atmosphere.
- Plug other ends of both the ports.
- If manometer is also used for pressure measurement, ensure that a different tapping is provided for it.
- Protect Pressure Transmitter from direct contact of water and other liquids.

2.6 Cable and Wiring of sub-system and analyzer



Lay down the cables from the sub-systems to the Signal Conditioning unit. Use the below given check list to make sure that all the cables are laid as per the specifications given in the above section.



➤ **Power supply cable** for Panel unit :
3 core, 14/36 gauge, 5A Mains Power Cord with Molded 3 pin male socket connection & other end open.

➤ **Special Cable from the oxygen sensor** to the Signal Conditioning unit.

➤ **Shielded 2 core cable** from :

Cable Connection	EffiMAX 1000	EffiMAX 2000	EffiMAX 3000	EffiMAX 4000
1. Stack temperature transmitter to Panel.	-	√	√	√
2. Feed water temp. Transmitter to Panel.	√	√	√	√
3. Ambient temperature Transmitter to Panel.	-	√	√	√
4. Steam temperature transmitter to Panel.	√	√	√	√
5. Steam flow meter to Panel.	√	√	√	√
6. ID Pressure Transmitter to Panel.	-	√	-	√

Installation

7. Blowdown valve to Panel.	√	√	√	√
8. BBCS Sensor cable to Panel	√	√	√	√
9. ID Output to Variable Frequency Drive.	-	√		√
10. FD Output to Variable Frequency Drive.	-	√	-	√
11. Feeder Output to Variable Frequency Drive.	-	√	-	√
12. Drum level control Output to control valve.	-	√	-	√
13. Burner ON/OFF contactor to the Panel.	√	√	√	√
14. Feeders Input to Panel	√	-	√	√

- **LAN cable** from the Effisense from panel to Effisense CPU.
- **TDS Special cable** from :
 1. TDS sensor to the panel.



✓ Please refer to each mechanical and electrical installation sub-section for specific wiring diagrams and directions.



✓ Use Proper size of lug suitable for 0.5 to 1 sqmm wire with length of 6-8 mm for termination on both analyzer and sub-system side.



✓ Use Proper size of ferrule suitable for 1 to 1.5 sq. mm wire for terminal number identification.



✓ Use weatherproof cable glands to keep the water, oil, and moisture entering inside the analyzer unit.

✓ Connect all the wires coming from the field mounted sensors to the effiMAX panel terminals.

2.7 Connection Details

2.7.1 Terminal Connection Details (Connect as per the panel drawings).

Note:

PE= POWER EARTH

IE= INSTRUMENT EARTH



The Toroidal Transformer gets the supply from the Signal Conditioning Motherboard. Please do not turn the unit ON unless proper connection is done.

The O2 Heater signal is mains 115V/230V hence do not touch the connectors wherever caution is indicated.

To prevent the system from Electrical noise / transients on Earth Line, please connect separate Instrument Earth to the Earth terminal screw provided on the Signal Conditioning Enclosure.

2.7.2 Terminal Connection Diagram:

Group Marker	Terminal No	Connection Details
Panel Input 230VAC 50Hz	1	Live
	2	Neutral
	3	Earth
	4	Instrument Earth
24VDC BB1		For internal 24vdc
AITB1	1	Ambient TT
	2	
	3	Steam TT
	4	
	5	Stack TT
	6	
	7	FW TT
	8	
	9	Steam Flow
	10	
	11	Feeder 1
	12	
	13	Input from BBCS Sensor: TDS Input (Yellow) TDS Input (Red)
	14	
	15	Input from BBCS Sensor: Blowdown Temp Input (White) Blowdown Temp Input (White)
	16	

Installation

AITB2	1	O2 Probe (Brown)
	2	O2 Probe (Brown-White)
	3	O2 Probe (Green)
	4	O2 Probe (Green-White)
	5	Drum Level
	6	
	7	ID Press
	8	
	9	Sup Steam Pr/NC
	10	
	11	Feeder 1
	12	
	13	Feeder 2
	14	
	15	Feeder 3
	16	
	17	Feeder 4
	18	
AITB3	1	Feeder 5
	2	
	3	Feeder 6
	4	
	5	Flexi 1
	6	
	7	Flexi 2
	8	
	9	Flexi 3
	10	

	11	Flexi 4
	12	
	13	Flexi 5
	14	
	15	Flexi 6
	16	
AITB4	1	Flexi 7
	2	
	3	Flexi 8
	4	
	5	Flexi 9
	6	
	7	Flexi 10
	8	
	9	Flexi 11
	10	
	11	Flexi 12
	12	
	13	NC
	14	
	15	NC
	16	

Installation

AOTB1	1	O2_RxTx
	2	
	3	TDS_RxTx
	4	
	5	O2_PID_OP
	6	
	7	FD1_OP
	8	

AOTB2	1	DL_OP
	2	
	3	FD2_OP
	4	
	5	ID_OP
	6	
	7	Feeder1_OP
	8	

AOTB3	1	Feeder2_OP
	2	
	3	Feeder3_OP
	4	
	5	Feeder4_OP
	6	
	7	Feeder5_OP
	8	

AOTB4	1	Feeder6_OP
	2	
	3	NC
	4	
	5	NC
	6	
	7	NC
	8	

DITB1	1	Boiler On/Off
	2	
	3	NC
	4	
	5	NC
	6	
	7	Superheated Blowdown Valve I/P
	8	
	9	NC
	10	
	11	AM_Stn1
	12	
	13	AM_Stn2
	14	
	15	AM_Stn3
	16	
DITB2	1	AM_Stn4
	2	

Installation

	3	AM_Stn5
	4	
	5	AM_Stn6
	6	
	7	AM_Stn7
	8	
	9	AM_Stn8
	10	
	11	NC
	12	
	13	NC
	14	
	15	NC
	16	

DOTB1	1	Blowdown Valve 230VAC L (Through 1 A fuse)
	2	Blowdown Valve 230VAC N
	3	NC
	4	
	5	NC
	6	
	7	NC
	8	

O2 Heater	1	O2 Probe Blue (Through 4 A fuse)
	2	O2 Probe Black

2.8 Commissioning the Product

- Each sub-system must be properly installed, commissioned and maintained to ensure correct efficiency readings. Please refer to each sub-system's section to properly commission your EffiMAX.
- After completion of all the installation and wiring, SWITCH ON the unit.
- Click on Restore to Default on Product page and check the range sheet as shown below to confirm that the values of all the parameters (like the maximum and the minimum values of the Steam Flow Rate) are as per your application.

Default Ranges:

Parameter	Minimum Range	Maximum Range
Stack Temperature	0 °C	400 °C
Ambient Air Temperature	0 °C	100 °C
Steam Temperature	0 °C	300 °C
Feed water Temperature	0 °C	200 °C
Stack Oxygen	0 %	20.9 %
Steam Flow	0.0 kg/h	5000 kg/h
Feeder 1	0.0 kg/hr	1300kg/hr
Feeder 2	0.0 kg/hr	1300kg/hr
Feeder 3	0.0 kg/hr	1300kg/hr
Feeder 4	0.0 kg/hr	1300kg/hr
Feeder 5	0.0 kg/hr	1300kg/hr
Feeder 6	0.0 kg/hr	1300kg/hr
Steam Pressure	0.0 kg/cm ²	16.0 kg/cm ²
ID Pressure	-25 mmWC	25 mmWC

Installation

- In case you need to change any of these, please refer to the individual sub system details given in section 4 of this manual.
- In applications where Oxypro has been supplied, please ensure that the dedicated electronics of the Oxypro (SME5) is powered on. It takes about 30 minutes for the sensor to heat up to the operating temperature. Correct oxygen readings will be shown only after this time.
- The default timer settings for the BBCS are
 - 30 minutes between purges
 - 30 seconds for the purge cycle
 - 20 seconds for each blow-down
 - 20 seconds between each blow-down
- Please refer to BBCS details in section 5 of this manual to study the automatic blow-down controller operation and for making changes to the timer values if required.
- Although boiler efficiency is continuously displayed on the unit, it is updated only when the Burner On/Off signal is present. The updating starts about 20 seconds after the signal goes high and is then updated continuously till the signal is present. The Efficiency and losses values are held made 0 when the signal goes low. The parameters being monitored and measured directly are still updated continuously.
- Calculate the fuel flow for solids by measuring the fuel/rpm/hr & then enter the feeder table accordingly.
- Monitor the system before taking control actions from the effiMAX panel, once the system is stable start taking control loops one by one in auto mode.
- Start with Feeder control which is based on steam pressure, then take FD fan in control based on O2 levels & finally ID in auto mode which is based on furnace pressure.

- Ensure that proper negative draft is maintained in furnace.
- For detailed sensor installations refer Commissioning software & videos prepared for those sensors.

- **This completes the commissioning of EffiMAX.**

SECTION 3: Eversense INSTALLATION

- To view Data on the computers in LAN through EffiSense Software, refer installation guidelines of Eversense.
- Ethernet settings for eversense machine:

IP Address: 192.168.1.200
Subnet Mask: 255.255.255.0
- System Settings:
 1. Product: effiSENSE
 2. Logo: effiSENSE
 3. No of rows in Device Settings: 200.

Not secure | 192.168.1.200/eversense/hc/generics/settings

everSENSE

FORBES MARSHALL

Welcome superuser

HOME TRENDS REPORTS ALARMS SETTINGS HELP LOGOUT

Settings Section

- Plant Management
 - Plant Settings
 - User Specific Parameters
 - Benchmark Configuration
 - Param Asset Configuration
 - everConnect Configuration
- User Management
 - Change Password
 - User Configuration
 - User Type Configuration
 - Custom Report Settings
 - Batch Param Configuration
 - Export Report
 - Email Configuration
 - Protocol Settings
 - Derived Tag Configuration

Plant Name: FM

Plant Address: India

Shift Timings: Shift 1: 06:00, Shift 2: 14:00, Shift 3: 22:00

Day Definition: Standard

Auto delete minute data older than: 9 Months **Warning: Data once deleted cannot be recovered**

Max Rows in Device Settings: 200

Product: eversENSE, Logo: eversENSE

Date Restoring: -- select --

Save Reset

Copyright: © 2020 Forbes Marshall Pvt. Ltd. All Rights Reserved.

- **Device Settings:**

1. **Channel Configuration:**

- Add Device: Select respective variant name from drop down list.
- IP address: IP address of the ER CPU port in use.
- Port – 502
- Channel Type- Ethernet.
- Click on Save to reflect the changes in settings.

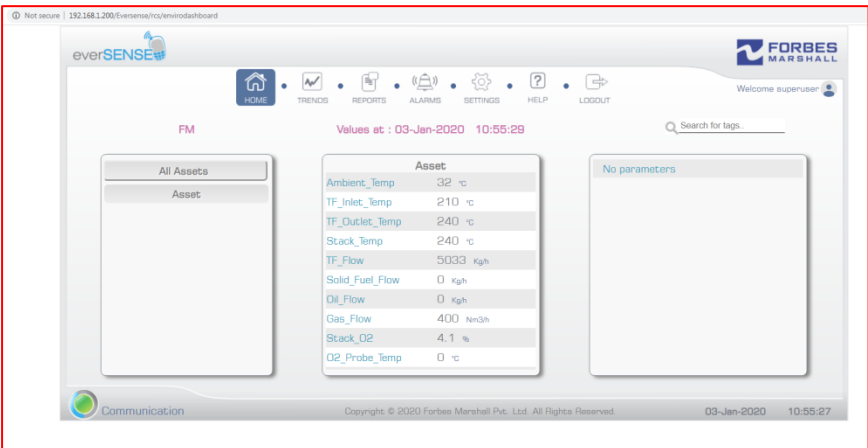
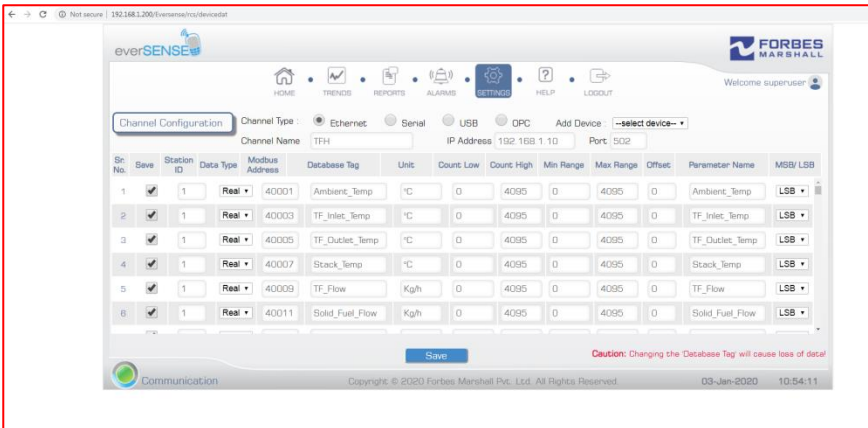

SECTION 4: OPERATING EFFIMAX

4.1 Operating the System from Plant Level

4.1.1 EffiMAX Display:

- After powering up, the first screen (Mimic Screen) displayed on HMI displays all the measured parameter values from the field and the calculated efficiency value with the losses.
- The figure given below gives the details of the Display unit. This screen is called the **Mimic** Screen. There are four main screens as below. You can change over from one screen to another by touching / clicking these buttons.
- The Mimic screen contains the link to the following screens:
 1. Flexi
 2. Trends
 3. Alarms
 4. Settings

Mimic Screen:

The HMI has 2 mimic screens :

1. Mimic 1 : All Monitoring parameters
2. Mimic 2 : All control related parameters

The parameters displayed on these screens will be updated after every second.

Mimic 1 :

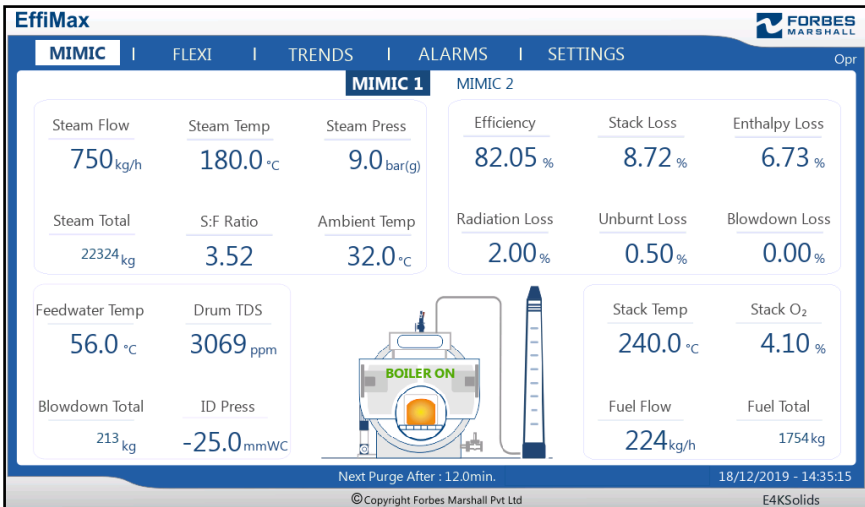

Operating EffiMAX

Mimic 2 :



The Trends button on each control displays the Trends of that control loop in the Trends section of this page. And depending on the no. of feeders configured, those many feeder outputs will be displayed on the Feeder O/P section.

Black Mimic :

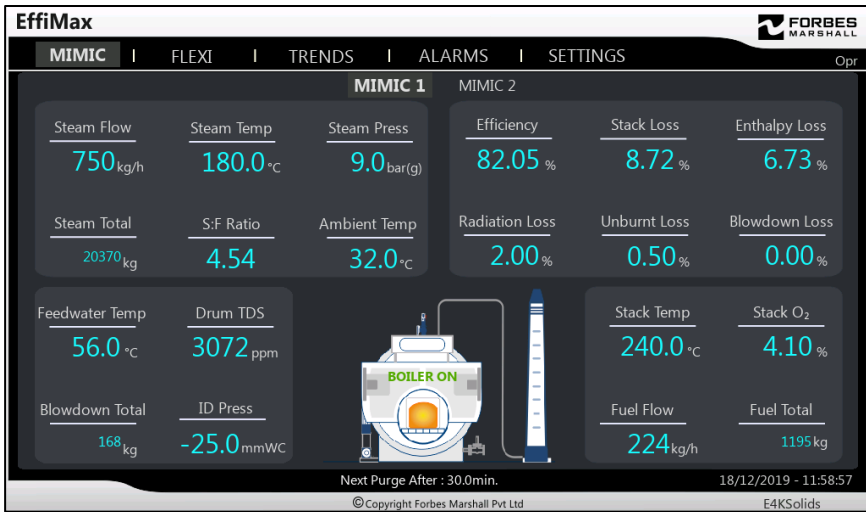

One more feature of dark theme is provided, it enhances visual ergonomics by reducing eye strain and providing comfort of use at night or in dark environments.

Flexi Screen:

The Flexi screen shows real time values of the additional parameters configured in effiMAX. Maximum 12 parameters can be configured in one system.

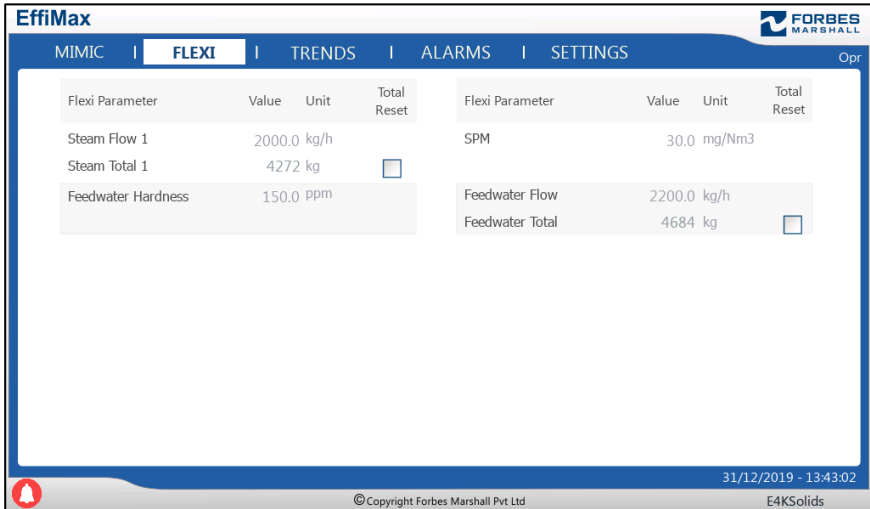

The screenshot displays the EffiMax interface with the 'FLEXI' tab selected. The interface includes a navigation bar with 'MIMIC', 'FLEXI', 'TRENDS', 'ALARMS', and 'SETTINGS'. The 'FLEXI' section contains two tables of parameter data. The first table lists 'Steam Flow 1' (2000.0 kg/h), 'Steam Total 1' (4272 kg), and 'Feedwater Hardness' (150.0 ppm). The second table lists 'SPM' (30.0 mg/Nm³), 'Feedwater Flow' (2200.0 kg/h), and 'Feedwater Total' (4684 kg). A 'Total Reset' checkbox is present for 'Steam Total 1' and 'Feedwater Total'. The bottom status bar shows a date and time of 31/12/2019 - 13:43:02, a copyright notice for Forbes Marshall Pvt Ltd, and the identifier E4KSolids.

Flexi Parameter	Value	Unit	Total Reset
Steam Flow 1	2000.0	kg/h	
Steam Total 1	4272	kg	<input type="checkbox"/>
Feedwater Hardness	150.0	ppm	

Flexi Parameter	Value	Unit	Total Reset
SPM	30.0	mg/Nm ³	
Feedwater Flow	2200.0	kg/h	
Feedwater Total	4684	kg	<input type="checkbox"/>

31/12/2019 - 13:43:02
© Copyright Forbes Marshall Pvt Ltd
E4KSolids

This screen shows parameter's live value, unit & its totalized value (if selected from settings). The totalizer can be reset from this screen by turning ON the checkbox.

Trends Screen:

The Trends screen shows real time Trends in groups. The groups are created as per the type of parameters.

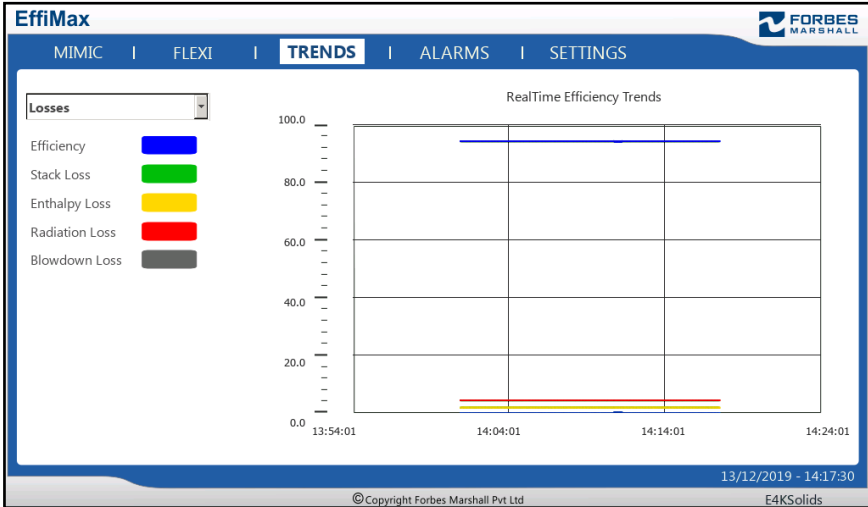

Option No.	Groups
1	Temperatures
2	Flow
3	Losses
4	Percentage

Option No.	Groups
5	Feeders
6	Others
7	Flexi Inputs 1
8	Flexi Inputs 2

Alarm Screen:

The alarm screen displays the alarm values of different parameters which are deviated either from the high limit values or the lower limit values.

The active alarms are displayed on Active Alarms screen with red background with State being displayed as “Triggered not Acked”. The alarm can be acknowledged by ACK button on this screen. The alarms which were active but its condition has now become healthy are shown in the Alarms History page which can be opened by clicking on the alarm History button on this screen. An array of last 15 alarms will be shown on screen.

The screenshot shows the EffiMax interface with the 'ALARMS' tab selected. The 'Active Alarms' section contains a table with the following data:

Select	Time	Description	State
<input type="checkbox"/>	13 Dec 2019 10:3...	Stack Temp less than Low SP	Not Triggered
<input type="checkbox"/>	13 Dec 2019 11:2...	Stack Temp higher than High SP	Not Triggered Not ...
<input type="checkbox"/>	13 Dec 2019 10:3...	Steam Temp less than Low SP	Not Triggered
<input type="checkbox"/>	13 Dec 2019 10:3...	Steam Temp higher than High SP	Not Triggered
<input type="checkbox"/>	13 Dec 2019 10:3...	Steam Pr. less than Low SP	Not Triggered
<input type="checkbox"/>	13 Dec 2019 10:3...	Steam Pr. higher than High SP	Not Triggered
<input type="checkbox"/>	13 Dec 2019 10:3...	FW Temp less than Low SP	Not Triggered
<input checked="" type="checkbox"/>	13 Dec 2019 12:0...	FW Temp higher than High SP	Triggered Not Acked
<input type="checkbox"/>	13 Dec 2019 10:3...	Steam Flow less than Low SP	Not Triggered
<input type="checkbox"/>	13 Dec 2019 10:3...	Steam Flow higher than High SP	Not Triggered

Below the table are controls: 'Check/Uncheck All', a 'Filter' dropdown set to 'Show All', and 'Ack', 'Reset', and 'Save' buttons. The bottom status bar shows the date '13/12/2019 - 12:05:44' and 'E4KSolids'.

Settings Screen:

The settings screen contains the following options:

- 1. O2 Calibration:** To calibrate the Oxygen analyzer with standard gases.
- 2. PID Controller:** To adjust the PID parameters of O2 Probe temperature, Feeder, ID, FD and Drum Level Controls.
- 3. Boiler Data:** Boiler specific data is entered on this screen.
- 4. Fuel type:** These settings are used select the type of fuel likewise FO, HUSK or Coal.
- 5. Blow Down:** To calibrate the TDS sensor as well adjustment for purge time.
- 6. Limits:** To specify Min & Max limits for the calculated variables.
- 7. Range:** This screen is for entering the transmitter ranges.
- 8. System:** System Screen is used to check and set date, time, brightness of HMI, IP address of HMI, AI/AO/DI/DO connection details navigations, etc.
- 9. Feeder:** Feeder screen is used to calibrate the fuel flow of each feeder (max. 6 feeders).
- 10. Product:** To select the EffiMAX variants, type of fuel flow meter, type of Density calculation and type of Oxygen signal as well.
- 11. Alarm Limits:** This screen is used to set the high & low Alarm Limits of the parameters.

For detailed explanation on the Settings screen please refer Assembly & Testing section.

4.2 Operational Guidelines

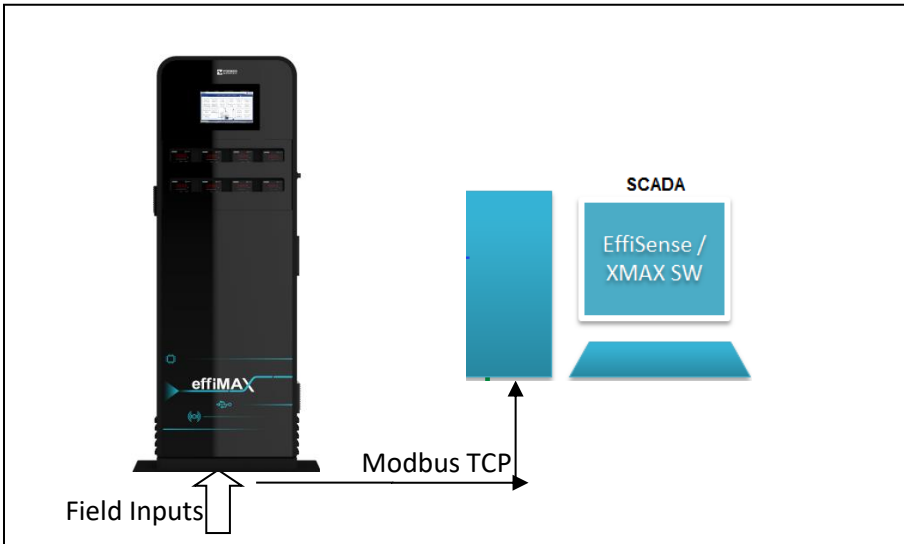

Fig. 5 Hardware Architecture

As shown in the diagram, the effiMAX consists of Panel unit and data logging unit. The panel unit is with a touch screen HMI which will display the online boiler data. The product performs following tasks simultaneously:

- Accepts inputs from all the field-mounted sensors.
- Displays the readings of all the parameters with their units.
- Computes individual losses of the boiler and the over-all efficiency.
- Directly or indirectly calculates the steam to fuel ratio from the consumption & generation of the boiler (depending on the variant selection).
- Measures and controls the TDS of the boiler drum water.
- Maintains the O2 cell operating temperature.
- Maintains the Steam pressure through Feeder control logic.

- Maintains the ID pressure through ID fan control logic.
- Maintains Oxygen levels through FD fan control logic.
- Provides an interface to the user for programming the required parameters.
- Provides remote data interface through LAN or any client server based network.
- Provides remote health checkup of the boiler house by viewing data remotely from any geographical place through internet.

Below mentioned settings needs to be done specific to the customer's site.

Operating EffiMAX

Screens to be set as per the variant selection:

Sr. No.	Screens Visible	EffiMAX 1000	EffiMAX 2000	EffiMAX 3000	EffiMAX 4000
1	O2 Calibration	-	√	√	√
2	PID Controller	-	√	√	√
	ID Fan Control	-	-	-	√
	FD Fan Control	-	-	-	√
	Feeder Control	-	-	-	√
	Drum Level Control (Optional)	-	-	-	√
3	Boiler Data	√	√	√	√
4	Fuel Type	√	√	√	√
5	Blowdown	(Optional)	√	√	√
6	Limits	√	√	√	√
7	Range	√	√	√	√
8	Feeder	√	-	√	√
9	Product	√	√	√	√
10	Alarms	√	√	√	√

4.2.1 The O2 calibration screen:

- To calibrate the Oxygen analyzer with standard gases.

Please perform the single point calibration for the O2 probe:

1. Ensure that boiler is in off condition and probe temperature is maintained at 800 deg C.
2. Open the sensor calibration port of O2 sensor.
3. Press **Calibrate Span** button.
4. Connect the test gas to the calibration port.
5. Enter the calibration gas O2 percentage value.
6. Press **Calibrate Slope** button.

EffiMax FORBES MARSHALL

MIMIC | FLEXI | TRENDS | ALARMS | **SETTINGS**

O₂ Cal | PID | Boiler Data | Fuel Type | Blowdown | Limits | Range

System | Feeder | Product | Alarm Limits

O₂ Calibration O₂ Calibration is not allowed while boiler is ON BOILER ON

Parameter	Value	Calibration Type	Parameter	Current	New	Action
Furnace Temp. (°C)	798.0	Manual	Cell Constant	-5.00	<input type="text" value="-5.00"/>	<input type="button" value="Save"/>
Stack O ₂ (%)	20.90		Slope	45.0	<input type="text" value="45.0"/>	
Actual Count	0	Span	Cell Constant	-5.00	-10.00	<input type="button" value="Calibrate"/>
Cell Constant	-10.00					<input type="button" value="Save"/>
		Slope	Test Gas O ₂ (%)		<input type="text" value="2.0"/>	<input type="button" value="Calibrate"/>
			Slope	45.0	-4.9	<input type="button" value="Save"/>

13/12/2019 - 12:02:17

© Copyright Forbes Marshall Pvt Ltd E4KSolids

4.2.2 PID Controller screen:

- To adjust the PID parameters of Oxygen Probe Temperature control.

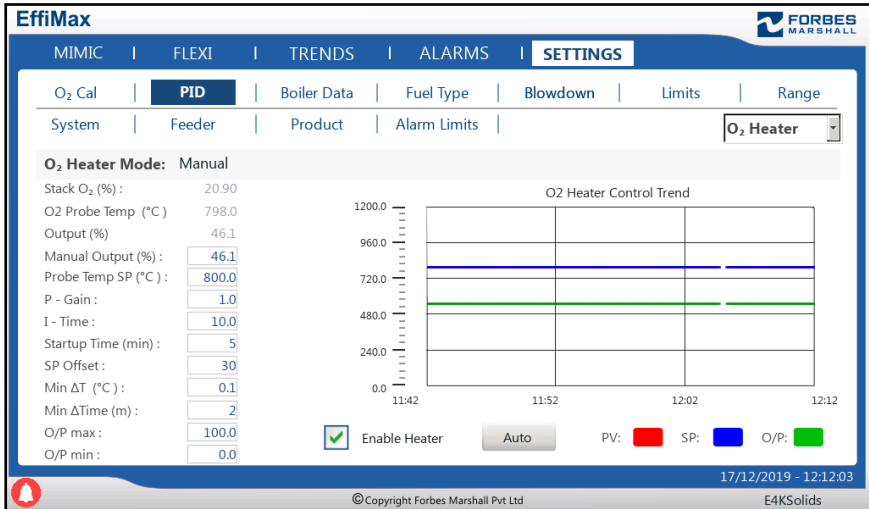

Below mentioned are the default values for the PID control:

1. **Set Point** – 800 °C
2. **Proportional Gain** – 1
3. **Integral Time** – 10 sec
4. **Startup Time** – 5 min
5. **SP Offset** – 30 °C
7. **Minimum Delta Temperature** – 0.1 °C
8. **Minimum Delta Time** – 2 min
9. **O/P Max** – 75%
10. **O/P Min** – 0%

Bump less transfer: To avoid Sudden changes while switching from Manual to Auto mode and vice versa.

4.2.3 Boiler Data:

- Boiler specific data is entered on this screen.

EffiMax

MIMIC | FLEXI | TRENDS | ALARMS | **SETTINGS**

O₂ Cal | PID | **Boiler Data** | Fuel Type | Blowdown | Limits | Range

System | Feeder | Product | Alarm Limits

Boiler Data

Boiler Capacity (kg / h)	1000.0	Fuel Density (kg/L)	1.00	S:F Ratio Averaging Time (min)	2
Oxygen Cutoff Value (%)	25.0	Fuel Cutoff Value (kg / h)	10	Boiler Unburnt Loss (%)	2.0
Boiler Startup Time (s)	10	Steam Density	5.164	Steam Enthalpy	663.567
GA Gain Input A1	1.000	BA Gain Input A1	0.000	Max. Steam Pressure (bar(g))	16.0
GB Gain Input A2	1.000	BB Gain Input A2	0.062	Boiler On-Off Count	4
GC Gain Input A3	1.000	BC Gain Input A3	0.911		
GO Gain Output C	1.578	BO Bias Output C	0.000		

Reset Totaliser

Steam | Blowdown | Fuel | Boiler OnOff Count

13/12/2019 - 12:02:54

© Copyright Forbes Marshall Pvt Ltd E4KSolids

a) Boiler Capacity:

The Steam generation capacity of Boiler in kg/h is entered here.

b) Boiler Startup Time:

This indicates the time duration for the combustion to stabilize. The efficiency calculation starts after this initial time has elapsed.

c) Oxygen Cut Off Value:

This value is used to display the boiler status in case Boiler on/off signal is not connected. If the value set is 15.0, then software presumes that if Oxygen value is greater than 15.0 % the boiler is off.

d) Boiler Un-burnt Loss:

This loss is manually entered to take care of the un-burnt losses which are not measured.

e) Fuel density:

This entry indicates the density of the fuel being fed in. For Solid fuels this value will be 1.

f) S:F Ratio Averaging Time:

This period is the time during which the averaging of S:F ratio is done. By default it is 30 mins. This value is important to get the accurate S:F ratio.

g) Fuel Cutoff Value:

System has a provision to detect Boiler On/OFF on fuel flow value if digital contact is unavailable. Fuel flow cut off value indicates the threshold value below which boiler will be considered as OFF.

h) Steam Density:

This is calculated parameter based on the Steam Temp and Steam Pr., this will be used when Steam flow input is Volumetric.

i) Steam Enthalpy:

This is calculated parameter based on the Steam Temp and Steam Pr., this will be used for direct efficiency calculations.

j) Constants (GA, GB, BA, BB...):

This is calculated parameter based on orifice plate parameters; this will be used for delta P based steam flow calculations.
Contact Forbes Marshall representative for this data.

k) Boiler On-Off Count:

This will indicate the total number of times boiler shutdown, value will be reset after 65535.

l) Reset Totalizers:

These 4 totalizer buttons to be used to reset that specific totalizer value to zero.

4.2.4 Fuel Type:

- These settings are used select the type of fuel likewise HUSK Coal, etc.
- Choose the type of fuel being used in the boiler.
- By changing the fuel type the constants related to each fuel will change accordingly. And these values are taken for further calculations.
- effiMAX is a versatile unit designed to run on various types of fuels.
- The fuel type selection is important because the efficiency calculations use different types of constants (like – calorific value of fuel, etc.) which are specific to each type of fuel.
- The fuel type of your boiler is factory set.

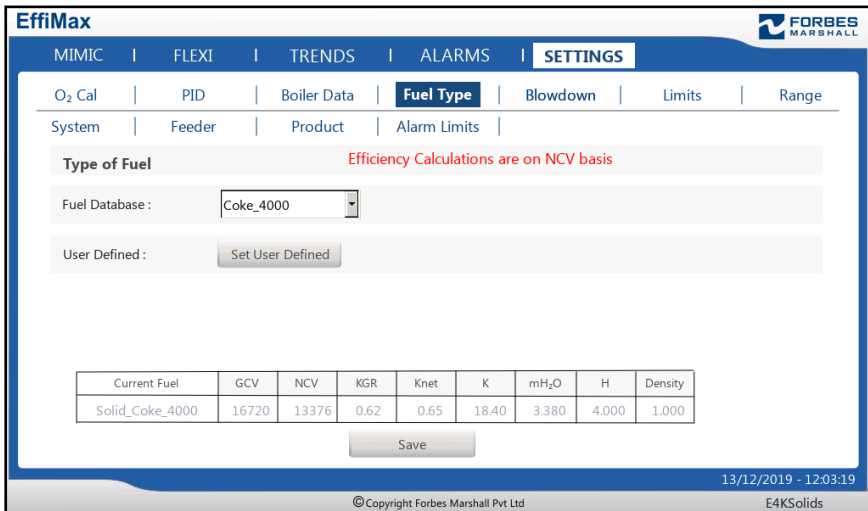

EffiMAX FORBES MARSHALL

MIMIC | FLEXI | TRENDS | ALARMS | **SETTINGS**

O₂ Cal | PID | Boiler Data | **Fuel Type** | Blowdown | Limits | Range

System | Feeder | Product | Alarm Limits

Type of Fuel Efficiency Calculations are on NCV basis

Fuel Database :

User Defined :

Current Fuel	GCV	NCV	KGR	Knet	K	mH ₂ O	H	Density
Solid_Coke_4000	16720	13376	0.62	0.65	18.40	3.380	4.000	1.000

13/12/2019 - 12:03:19

© Copyright Forbes Marshall Pvt Ltd E4KSolids

Note: Click on Save, to reflect the changes in calculation.

4.2.5 The Blowdown Screen:

EffiMax

MIMIC | FLEXI | TRENDS | ALARMS | **SETTINGS** | Opr

O₂ Cal | PID | Boiler Data | Fuel Type | **Blowdown** | Limits | Range

System | Feeder | Product | Alarm Limits

Blowdown Control Mode: Manual **BOILER ON**

Current TDS (ppm)	368	Time between Purge Cycles (mins)	30
TDS Constant K	0.84	Purge Time (sec)	30
TDS Resistance (ohm)	399	Blowdown Time (sec)	20
TDS Setpoint (ppm)	3500	TDS Calibrated Value (ppm)	3000
Blowdown Temp. (°C)	175.0	TDS Deadband (ppm)	50

Purge Auto

19/12/2019 - 15:22:03
© Copyright Forbes Marshall Pvt Ltd E4KSolids

- To calibrate the TDS sensor as well adjustment for purge time.

Calibration of TDS Sensor:

1. Select Manual Mode.
2. Press **Purge** & collect the sample of blowdown water.
3. Ensure that there is no flashing.
4. Do not purge again after taking sample till calibration data is entered.
5. Take a sample of the blowdown water in a beaker.
6. Measure its TDS with a calibrated and certified meter or the Lab test value of blowdown water.

7. Enter the TDS value in TDS calibration value.
8. Now Press **Purge** button & while the purge is ON, press **Calibrate** button.
9. The system is now calibrated to the actual TDS Value.
10. Now select Auto mode which will blowdown after select interval.

The screenshot shows the EffiMAX control interface. At the top, there is a navigation bar with 'SETTINGS' selected. Below it, a sub-menu shows 'Blowdown' highlighted. The main content area displays the following settings:

Blowdown Control Mode: Auto		Purge Mode On		BOILER ON	
Current TDS (ppm)	442	Time between Purge Cycles (mins)	<input type="text" value="30"/>		
TDS Constant K	1.04	Purge Time (sec)	<input type="text" value="30"/>		
TDS Resistance (ohm)	400	Blowdown Time (sec)	<input type="text" value="20"/>		
TDS Setpoint (ppm)	<input type="text" value="3500"/>	TDS Calibrated Value (ppm)	<input type="text" value="6000"/>		
Blowdown Temp. (°C)	180.0	TDS Deadband (ppm)	<input type="text" value="50"/>		

At the bottom of the screen, there is a 'Manual' button and the text 'Next Purge After : 10.0min.'. The footer shows '© Copyright Forbes Marshall Pvt Ltd' and 'E4KSolids'.

Note: Blowdown is inactive once the Boiler is OFF, so boiler won't drain during long OFF cycles.

4.2.6 Limits Screen:

- To set Min & Max limits for the calculated parameters
- With this page, we can configure the minimum & maximum display value limits for all the calculated parameters.

The screenshot shows the EffiMAX interface with the 'LIMITS' screen selected. The interface includes a navigation bar with tabs for MIMIC, FLEXI, TRENDS, ALARMS, and SETTINGS. Below the navigation bar, there are sub-tabs for O₂ Cal, PID, Boiler Data, Fuel Type, Blowdown, Limits (selected), and Range. Further down, there are tabs for System, Feeder, Product, and Alarm Limits. The main content area displays a table of parameters with their respective minimum and maximum values.

Parameter	Min.	Max.
Steam Pr. (bar g)	0.0	40.0
S : F Ratio	0.0	20.0
Boiler Efficiency (%)	0.0	100.0
TDS Value (ppm)	0	20000
Stack Oxygen (%)	0.0	20.9
Stack Loss (%)	0.0	100.0
Enthalpy Loss (%)	0.0	100.0
Radiation Loss (%)	0.0	100.0
Blowdown Loss (%)	0.0	100.0

13/12/2019 - 12:04:05
© Copyright Forbes Marshall Pvt Ltd E4KSolids

4.2.7 Range Screen:

- For setting minimum and the maximum ranges of the standard field mounted sensors.

EffiMax **FORBES MARSHALL**

MIMIC | FLEXI | TRENDS | ALARMS | **SETTINGS**

O₂ Cal | PID | Boiler Data | Fuel Type | Blowdown | Limits | **Range**

System | Feeder | Product | Alarm Limits | Standard ▾

Parameter	Min. Count	Max. Count	Min. Range	Max. Range	Actual Count	Actual Value
Ambient Temp	10486	52428	0	100	0	0.0 °C
Feed Water Temp	10486	52428	0	200	0	0 °C
Stack Temp	10486	52428	0	400	0	0 °C
Mass Steam Flow	10486	52428	0	1000	0	0 kg / h
Feeder 1	10486	52428	0	1300	0	0 rpm
Steam Temp	10486	52428	0.00	300.00	0	0.00 °C
ID Pressure	10486	52428	0.00	25.00	0	0.00 mmWC
Drum Level	10486	52428	0	100	0	0 %

Next

13/12/2019 - 12:08:12

© Copyright Forbes Marshall Pvt Ltd E4KSolids

EffiMax **FORBES MARSHALL**

MIMIC | FLEXI | TRENDS | ALARMS | **SETTINGS**

O₂ Cal | PID | Boiler Data | Fuel Type | Blowdown | Limits | **Range**

System | Feeder | Product | Alarm Limits | Standard ▾

Parameter	Min. Count	Max. Count	Min. Range	Max. Range	Actual Count	Actual Value
Stack Oxygen Cell EMF	10486	52428	0.00	125.00	0	0.00 mV
O ₂ Probe Temp	10486	52428	0.0	1200.0	0	0.0 °C
TDS	10486	52428	0	5000	10487	0 ppm
Blowdown Temp	10486	52428	0.0	250.0	0	0.0 °C
Feeder 2	10486	52428	0	1300	0	0 rpm

Previous

13/12/2019 - 12:08:38

© Copyright Forbes Marshall Pvt Ltd E4KSolids

Range Settings for Flexi parameters:

Flexi Parameter	Min. Count	Max. Count	Min. Range	Max. Range	Actual Count	Actual Value
Steam Flow 1	10486	52428	2000	10000	0	2000 kg/h
SPM	10486	52428	30	999	0	30 mg/Nm3
Feedwater Hardness	10486	52428	150	6000	0	150 ppm
Feedwater Flow	10486	52428	2200	15000	0	2200 kg/h

Above fig indicates default ranges configured for the Field sensors.

- In addition to the sensor ranges, actual count received from the I/O Module as well as its actual value is displayed.
- This screen would be very useful while commissioning the unit as it shows the Raw as well as scaled values of the sensors.
- The list of parameters changes with the type of product selected.
- The range of Stack Oxygen is normally -10.0mV to 125.00mV in case direct oxygen is measured.
- In case if Stack Oxygen is measured using dedicated electronics or any other analyzer, the range should be 0.0 to 20.9%.

4.2.8 System Screen:

The screenshot displays the 'System' settings page in the EffiMax HMI. The top navigation bar includes 'MIMIC', 'FLEXI', 'TRENDS', 'ALARMS', and 'SETTINGS'. Below this, a secondary menu shows 'O2 Cal', 'PID', 'Boiler Data', 'Fuel Type', 'Blowdown', 'Limits', and 'Range'. The 'System' section is active, showing configuration fields for Date (18/12/2019), Time (09:57:24), HMI IP (192.168.1.110), and Brightness (0-255, set to 255). A 'Load Testing Values' button is present. Below, the 'Connection Details' section shows status buttons for AI, AO, DI, and DO. The bottom status bar indicates the date and time (18/12/2019 - 09:57:24) and the user 'E4KSolids'.

- To set additional features like Date, Time, IP Address, Brightness level.
- In addition user can view Connection Details and its status for AI, AO, DI, and DO inputs.

The screenshot displays the 'Alarm Limits' page in the EffiMax HMI. The top navigation bar includes 'MIMIC', 'FLEXI', 'TRENDS', 'ALARMS', and 'SETTINGS'. Below this, a secondary menu shows 'O2 Cal', 'PID', 'Boiler Data', 'Fuel Type', 'Blowdown', 'Limits', and 'Range'. The 'Alarm Limits' section is active, showing two tables, AITB 1 and AITB 2, listing parameters and their current counts. AITB 1 includes parameters like Amb. Temp., Steam Temp., Stack Temp., Feedwater Temp., Steam Flow, Feeder1/Gas/Oil, TDS, and Blowdown Temp. AITB 2 includes parameters like Stack O2, O2 Probe Temp., Drum Level, ID Pr. /Firing FB, Sup. Steam Pr. / NC, Feeder2 /DF_Gas Flow, Feeder3, and Feeder4. The 'System' button is highlighted. The bottom status bar indicates the date and time (18/12/2019 - 09:57:42) and the user 'E4KSolids'.

AITB 1			AITB 2		
No.	Parameters	Counts	No.	Parameters	Counts
AIN1	Amb. Temp.	0	AIN1	Stack O2	0
AIN2	Steam Temp./ Steam Pr.	0	AIN2	O2 Probe Temp.	0
AIN3	Stack Temp.	0	AIN3	Drum Level	0
AIN4	Feedwater Temp.	0	AIN4	ID Pr. /Firing FB	0
AIN5	Steam Flow	0	AIN5	Sup. Steam Pr. / NC	0
AIN6	Feeder1/Gas/Oil	0	AIN6	Feeder2 /DF_Gas Flow	0
AIN7	TDS	10491	AIN7	Feeder3	0
AIN8	Blowdown Temp	0	AIN8	Feeder4	0

Operating EffiMAX

EffiMax  Opr

MIMIC | FLEXI | TRENDS | ALARMS | **SETTINGS**

O₂ Cal | PID | Boiler Data | Fuel Type | Blowdown | Limits | Range

System | Feeder | Product | Alarm Limits

AITB 3		
No.	Parameters	Counts
AIN1	Feeder5	0
AIN2	Feeder6	0
AIN3	Flexi Input 1	0
AIN4	Flexi Input 2	0
AIN5	Flexi Input 3	0
AIN6	Flexi Input 4	0
AIN7	Flexi Input 5	0
AIN8	Flexi Input 6	0

AITB 4		
No.	Parameters	Counts
AIN1	Flexi Input 7	0
AIN2	Flexi Input 8	0
AIN3	Flexi Input 9	0
AIN4	Flexi Input 10	0
AIN5	Flexi Input 11	0
AIN6	Flexi Input 12	0
AIN7	NC	0
AIN8	NC	0

Previous AO

18/12/2019 - 09:58:02

© Copyright Forbes Marshall Pvt Ltd E4KSolids

EffiMax  Opr

MIMIC | FLEXI | TRENDS | ALARMS | **SETTINGS**

O₂ Cal | PID | Boiler Data | Fuel Type | Blowdown | Limits | Range

System | Feeder | Product | Alarm Limits

AOTB 1		
No.	Parameters	Counts
AOUT1	O ₂ _RxTx	18714
AOUT2	TDS_RxTx	23020
AOUT3	O ₂ PID_OP	11325
AOUT4	FD1_OP	10486

AOTB 2		
No.	Parameters	Counts
AOUT1	DL_OP	10486
AOUT2	FD2_OP	10486
AOUT3	ID_OP	10486
AOUT4	F1_OP	10486

AOTB 3		
No.	Parameters	Counts
AOUT1	F2_OP	10486
AOUT2	F3_OP	10486
AOUT3	F4_OP	10486
AOUT4	F5_OP	10486

AOTB 4		
No.	Parameters	Counts
AOUT1	F6_OP	10486
AOUT2	NC	10486
AOUT3	NC	10486
AOUT4	NC	10486

AI DI

18/12/2019 - 09:58:22

© Copyright Forbes Marshall Pvt Ltd E4KSolids

EffiMax FORBES MARSHALL

MIMIC | FLEXI | TRENDS | ALARMS | **SETTINGS** Opr

O₂ Cal | PID | Boiler Data | Fuel Type | Blowdown | Limits | Range

System | Feeder | Product | Alarm Limits

DITB 1

No.	Parameters	Status
DIP1	Boiler ON/OFF	■
DIP2	Oil Flow Selection	■
DIP3	Gas Flow Selection	■
DIP4	Superheated Bldn Valve I/P	■
DIP5	Oil Pulse I/P	■
DIP6	AM Station 1	■
DIP7	AM Station 2	■
DIP8	AM Station 3	■

DITB 1

No.	Parameters	Status
DIP9	AM Station 4	■
DIP10	AM Station 5	■
DIP11	AM Station 6	■
DIP12	AM Station 7	■
DIP13	AM Station 8	■
DIP14	NC	■
DIP15	NC	■
DIP16	NC	■

AODO

18/12/2019 - 09:58:39

© Copyright Forbes Marshall Pvt Ltd E4KSolids

EffiMax FORBES MARSHALL

MIMIC | FLEXI | TRENDS | ALARMS | **SETTINGS** Opr

O₂ Cal | PID | Boiler Data | Fuel Type | Blowdown | Limits | Range

System | Feeder | Product | Alarm Limits

DOTB 1

No.	Parameters	Status
DO1	Blowdown valve	■
DO2	NC	■
DO3	NC	■
DO4	NC	■
DO5	NC	■
DO6	NC	■
DO7	NC	■
DO8	NC	■

DOTB 1

No.	Parameters	Status
DO9	NC	■
DO10	NC	■
DO11	NC	■
DO12	NC	■
DO13	NC	■
DO14	NC	■
DO15	NC	■
DO16	NC	■

DI

18/12/2019 - 09:58:58

© Copyright Forbes Marshall Pvt Ltd E4KSolids

4.2.9 ID Fan Screen:

ID PID screen is used to configure the parameters for ID pressure control. The firing table needs to be filled in to define the desired values at different load conditions. This table can be opened by clicking on the “Show” button in front of firing table. The min & max values of ID pressures should be entered on this page. The control logic will consider these values as a window under which ID pressure will be controlled through firing table output or through PID Output. If ID pressure value crosses these limits then control logic will override the control logic & change the damper position or VFD output in such a way that it gets back ID pressure in the desired limits.

The screenshot displays the EffiMax control interface for the ID Fan. The top navigation bar includes MIMIC, FLEXI, TRENDS, ALARMS, and SETTINGS. The current view is the SETTINGS screen, specifically the PID control section for the ID Fan. The interface shows various parameters and control options:

Parameter	Value	Mode/Control	Parameter	Value
Stack O ₂ (%)	4.10		P - Gain	1.0
ID Pr	-25.00		I - Time	10.0
Firing Rate (%)	4.5		Ramp Rate (%/sec)	2
Firing Table	<input type="button" value="Show"/>		ID Startup Time (sec)	10
Firing Table SP	-0.22 SP Mode (User /Table):	<input type="button" value="User Defined"/>	ID Start Air (%)	20
Firing Table OP	56.9 OP Mode (PID /Table):	<input type="button" value="PID"/>	Max Fuel Flow (Kg/hr)	5000.0
Manual Output	<input type="text" value="0.0"/> Mode (A /M):	<input type="button" value="Auto"/>	ID Pr Min (mmWC)	-7.00
Ramped ID Output	0.0 (0.0)		ID Pr Max (mmWC)	1.00
			ID Pr Low OP (%)	35.0
			ID Pr High OP (%)	65.0
			PID O/P Min (%)	0
			PID O/P Max (%)	100

Additional information: The screen indicates "Output is driven by Manual Mode". The status bar at the bottom shows the date and time as 19/12/2019 - 12:18:46 and the copyright notice for Forbes Marshall Pvt Ltd.

Cases:

1. Auto Mode:

- a) ID Pr Min = -7mmWC , Live Value = -8mmWC

ID FAN Output = ID Pr Low OP

So by running ID motor as slow as possible to reduce the -ve pressure in furnace.

- b) ID Pr Max = 1mmWC , Live Value = 2mmWC

ID FAN Output = ID Pr High OP

So by running ID motor as fast as possible speed to increase the -ve pressure in furnace.

- c) Live Value = -2mmWC (in band)

ID Fan Output = either derived by PID block or through Firing table based on the OP mode selection.

Set point also can be enter manually or derived through firing table based on the SP mode selection.

2. Manual Mode:

In manual mode user can set the ID Fan output as required.

Stack O2: It displays the “Live” O2 value in the stack.

ID Pr: It displays the “Live” ID pressure value in the furnace.

Firing Rate: % firing is calculated depending on the Boiler Load. Boiler load is indicated with the ratio of Actual Flow by Maximum fuel flow.

Firing Table: This table is used to feed the Set points & FAN OP as per the load, so as the load changes set points & OP's are derived from these tables.

Set point: Selection of Set point is based on the SP mode selection. This is the value of ID Pressure set by user or derived from firing table for a particular firing rate.

PID OP / Firing Table OP: Selection of output is based on the OP mode selection. This is the value of OP is derived by PID block or derived from firing table for a particular firing rate.

Manual Output: In manual mode user can set the ID Fan output as required by user.

ID Fan Output: This indicates the final output going to the VFD or damper of the ID fan. It is varied in the range of 0 to 100. The manual and the controller output will always be same in the auto mode of the controller to have “Bump less Transfer” during mode switch over. This takes care of the possibility of damage to the VFD for sudden drops in the RPM of the ID fan.

Mode: This helps to switch from auto to manual mode and vice versa. Manual Mode is used to bypass the control action and user can enter the Output as required from 0 – 100%.

Proportional Gain (P): Proportional value in the PID controller used to calculate the Output. This gain (P) should be tuned based on the response of the –ve draft in boiler & the boiler combustion.

Repeats / Min (I): Integral Value in the PID controller used to calculate the Output. This indicates the rate of output value updating in a minute. For ex. If I is set as 10, then $60\text{sec} / 10 = 6$. This means after every 6 sec output is re-calculated to control the damper / motor.

Ramp Rate: It is the Value entered to set the number of steps in one second expressed in %/sec.

ID Startup Time: It is the time duration for the boiler to stabilize.

ID Start Air: Value entered in this field is used as ID Fan OP for ID startup time duration. For ex.: In this case 20% ID fan OP for 10sec after boiler ON signal received.

Max Fuel Flow: This value indicates that amount of fuel will be consumed at maximum motor or operating RPM. This value is used to calculate the firing rate of the boiler hence should be precisely entered.

ID Pr Min: This value defines minimum ID pressure beyond which it can't be increase to avoid the back fire issue.

ID Pr Max: This value defines maximum ID pressure beyond which it can't be increase to avoid the back fire issue.

ID Pr Low O/P: This value is used to limit the damper opening or ID Fan motor speed to avoid the backfire issue & to run the trim loop in safe band.

ID Pr High O/P: This value is used to limit the damper opening or ID Fan motor speed to avoid the high -ve draft in furnace & to run the trim loop in safe band.

PID OP Min: This value is used to limit the PID output in Auto mode, so that output should not go below the minimum operating value.

PID OP Max: This value is used to limit the PID output in Auto mode, so that output should not go above the maximum operating value.

Operating EffiMAX

ID Fan Firing Table:

This table is used to feed the Set points & FAN OP as per the load, so as the load changes set points & OP's are derived from these tables.

On Firing table page settings are non-editable, to change any values click on Master Table.

The screenshot displays the EffiMax control interface. At the top, there is a navigation bar with the following tabs: MIMIC, FLEXI, TRENDS, ALARMS, and SETTINGS. The 'SETTINGS' tab is currently selected. The main content area is divided into two sections. On the left, there is a table titled 'ID Fan Firing Table' with the following columns: Firing, ID OP, ID Pr SP, FD OP, and O2 SP. The table contains 11 rows of data. On the right, there are four process parameters displayed: Steam Press (9.0 bar(g)), Stack O₂ (4.10%), Firing Rate (4.5%), and ID Press (-25.0 mmWc). Below these parameters, there is a red warning message: 'This is read only page... Click on Master Table to change the settings'. At the bottom of the interface, there are two buttons: 'Master Table' and 'Back'. The footer of the interface shows the copyright information: '© Copyright Forbes Marshall Pvt Ltd' and the date/time: '19/12/2019 - 12:19:08'. The logo for 'FORBES MARSHALL' is visible in the top right corner.

Firing	ID OP	ID Pr SP	FD OP	O2 SP
0	56.0	0.00	54.0	2.0
10	58.0	-0.50	56.0	2.4
20	60.0	-1.00	58.0	2.6
30	62.0	-2.00	60.0	3.0
40	64.0	-2.50	62.0	4.0
50	66.0	-2.80	64.0	5.0
60	68.0	-3.00	66.0	5.5
70	70.0	-4.00	68.0	6.0
80	72.0	-4.50	70.0	7.0
90	72.0	-5.00	70.0	8.0
100	72.0	-6.00	70.0	10.0

Steam Press: 9.0 bar(g)
Stack O₂: 4.10 %
Firing Rate: 4.5 %
ID Press: -25.0 mmWc

This is read only page... Click on Master Table to change the settings

Master Table Back

19/12/2019 - 12:19:08
E4KSolids
© Copyright Forbes Marshall Pvt Ltd

ID Fan Master:

As per the fuel changes values in firing table needs to be redefined as per the fuel quality, so maximum 3 fuel configuration can be saved in databases.

By selecting Fuel1, Fuel 2 or Fuel 3 from the drop down provided at right top corner, respective settings will be copied in actual firing table.

EffiMax **FORBES MARSHALL**

ID Press: -25.0 mmWC Stack O₂: 4.10 % Steam Press: 9.0 bar(g) Firing Rate: 4.5% Opr

FIRING (%)	Fuel 1				Fuel 2				Fuel 3				Fuel 1
	ID FAN O/P	FD FAN O/P	ID Pr. SP	O ₂ SP	ID FAN O/P	FD FAN O/P	ID Pr. SP	O ₂ SP	ID FAN O/P	FD FAN O/P	ID Pr. SP	O ₂ SP	
0	56.0	54.0	0.00	2.00	56.0	54.0	0.00	2.00	56.0	54.0	0.00	2.00	
10	58.0	56.0	-0.50	2.40	58.0	56.0	-0.50	2.40	58.0	56.0	-0.50	2.40	
20	60.0	58.0	-1.00	2.60	60.0	58.0	-1.00	2.60	60.0	58.0	-1.00	2.60	
30	62.0	60.0	-2.00	3.00	62.0	60.0	-2.00	3.00	62.0	60.0	-2.00	3.00	
40	64.0	62.0	-2.50	4.00	64.0	62.0	-2.50	4.00	64.0	62.0	-2.50	4.00	
50	66.0	64.0	-2.80	5.00	66.0	64.0	-2.80	5.00	66.0	64.0	-2.80	5.00	
60	68.0	66.0	-3.00	5.50	68.0	66.0	-3.00	5.50	68.0	66.0	-3.00	5.50	
70	70.0	68.0	-4.00	6.00	70.0	68.0	-4.00	6.00	70.0	68.0	-4.00	6.00	
80	72.0	70.0	-4.50	7.00	72.0	70.0	-4.50	7.00	72.0	70.0	-4.50	7.00	
90	72.0	70.0	-5.00	8.00	72.0	70.0	-5.00	8.00	72.0	70.0	-5.00	8.00	
100	72.0	70.0	-6.00	10.00	72.0	70.0	-6.00	10.00	72.0	70.0	-6.00	10.00	

Back

Any change in Fuel selection... will change Feeder OP ID & FD firing table settings in 19/12/2019 - 12:19:31

© Copyright Forbes Marshall Pvt Ltd E4KSolids

4.2.10 FD Fan Screen:

FD PID screen is used to configure the parameters for O₂ Control. The firing table needs to be filled in to define the desired values at different load conditions. This table can be opened by clicking on the “Show” button in front of firing table. The min & max values of O₂ should be entered on this page. The control logic will consider these values as a window under which O₂ will be controlled through firing table output or through PID Output. If O₂ value crosses these limits then control logic will override the control logic & change the damper position or VFD output in such a way that it gets back O₂ in the desired limits.

The screenshot displays the 'FD Fan Control' settings screen in the EffiMAX interface. The screen is titled 'EffiMAX' and 'FORBES MARSHALL'. The main menu includes MIMIC, FLEXI, TRENDS, ALARMS, and SETTINGS. The current view is 'SETTINGS' for 'FD Fan'. The screen shows various control parameters for O₂ control, including Stack O₂ (4.10), ID Pr (-25.00), Firing Rate (4.5), and Firing Table (Show button). The Firing Table SP is 2.18, and the SP Mode is User Defined. The Firing Table OP is 54.9, and the OP Mode is PID. The Manual Output is 0.0, and the Mode is Auto. The Ramped FD Output is 0.0 (0.0). The FD1 FAN Output is 0.0, and the FD1 Fan Ratio is 1.000. The screen also shows PID parameters: P - Gain (1.0), I - Time (10.0), Ramp Rate (%/sec) (2), FD Startup Time (sec) (10), FD Start Air (%) (20), Max Fuel Flow (Kg/hr) (5000.0), O₂ Min (%) (2.00), O₂ Max (%) (12.00), O₂ Low OP (%) (20.0), O₂ High OP (%) (100.0), PID O/P Min (%) (0), and PID O/P Max (%) (100). The screen is dated 19/12/2019 - 12:20:10 and has the copyright notice © Copyright Forbes Marshall Pvt Ltd and E4KSolids.

Cases:

1. Auto Mode:

d) O₂ Min = 2% , Live Value = 1%

FD FAN Output = O₂ High OP

So by running FD motor as fast as possible to increase the O₂ % in furnace.

e) O₂ Max = 12% , Live Value = 15%

FD FAN Output = O₂ Low OP

So by running FD motor as slow as possible to reduce the O₂ % in furnace.

f) Live Value = 6% (in band)

FD Fan Output = either derived by PID block or through Firing table based on the OP mode selection.

Set point also can be enter manually or derived through firing table based on the SP mode selection.

2. Manual Mode:

In manual mode user can set the FD Fan output as required.

Stack O2: It displays the “Live” O₂ value in the stack.

ID Pr: It displays the “Live” ID pressure value in the furnace.

Firing Rate: % firing is calculated depending on the Boiler Load. Boiler load is indicated with the ratio of Actual Flow by Maximum fuel flow.

Firing Table: This table is used to feed the Set points & FAN OP as per the load, so as the load changes set points & OP's are derived from these tables.

Set point: Selection of Set point is based on the SP mode selection. This is the value of O₂ set by user or derived from firing table for a particular firing rate.

PID OP / Firing Table OP: Selection of output is based on the OP mode selection. This is the value of OP is derived by PID block or derived from firing table for a particular firing rate.

Manual Output: In manual mode user can set the FD Fan output as required by user.

FD Fan Output: This indicates the final output going to the VFD or damper of the FD fan. It is varied in the range of 0 to 100. The manual and the controller output will always be same in the auto mode of the controller to have “Bump less Transfer” during mode switch over. This takes care of the possibility of damage to the VFD for sudden drops in the RPM of the FD fan.

Mode: This helps to switch from auto to manual mode and vice versa. Manual Mode is used to bypass the control action and user can enter the Output as required from 0 – 100%.

Proportional Gain (P): Proportional value in the PID controller used to calculate the Output. This gain (P) should be tuned based on the response of the O₂ probe & the boiler combustion.

Repeats / Min (I): Integral Value in the PID controller used to calculate the Output. This indicates the rate of output value updating in a minute. For ex. If I is set as 10, then 60sec / 10 = 6. This means after every 6 sec output is re-calculated to control the damper / motor.

Ramp Rate: It is the Value entered to set the number of steps in one second expressed in %/sec.

FD Startup Time: It is the time duration for the boiler to stabilize.

FD Start Air: Value entered in this field is used as FD Fan OP for FD startup time duration. For ex.: In this case 20% FD fan OP for 10sec after boiler ON signal received.

Max Fuel Flow: This value indicates that amount of fuel will be consumed at maximum motor or operating RPM. This value is used to calculate the firing rate of the boiler hence should be precisely entered.

O₂ Min: This value defines minimum O₂ beyond which it can't be reduced to avoid the back fire issue.

O₂ Max: This value defines maximum O₂ beyond which it can't be increase to avoid the heat losses.

O₂ Low O/P: This value is used to limit the damper opening or FD Fan motor speed to avoid the backfire issue & to run the trim loop in safe band.

O₂ High O/P: This value is used to limit the damper opening or FD Fan motor speed to avoid the high O₂ in furnace & to run the trim loop in safe band.

PID OP Min: This value is used to limit the PID output in Auto mode, so that output should not go below the minimum operating value.

PID OP Max: This value is used to limit the PID output in Auto mode, so that output should not go above the maximum operating value.

Operating EffiMAX

Firing Table:

This table is used to feed the Set points & FAN OP as per the load, so as the load changes set points & OP's are derived from these tables.

On Firing table page settings are non-editable, to change any values click on Master Table.

The screenshot displays the EffiMax control interface. At the top, there are navigation tabs: MIMIC, FLEXI, TRENDS, ALARMS, and SETTINGS. The current view is the 'Firing Table' page. The table lists firing rates from 0 to 100, with corresponding set points for ID OP, ID Pr SP, FD OP, and O2 SP. To the right of the table, there are four process parameters: Steam Press (9.0 bar(g)), Stack O₂ (4.10 %), Firing Rate (4.5 %), and ID Press (-25.0 mmWC). A red warning message states: 'This is read only page... Click on Master Table to change the settings'. At the bottom of the interface, there are two buttons: 'Master Table' and 'Back'. The footer shows the date and time '19/12/2019 - 12:20:36' and the copyright notice '© Copyright Forbes Marshall Pvt Ltd E4KSolids'.

Firing	ID OP	ID Pr SP	FD OP	O2 SP
0	56.0	0.00	54.0	2.0
10	58.0	-0.50	56.0	2.4
20	60.0	-1.00	58.0	2.6
30	62.0	-2.00	60.0	3.0
40	64.0	-2.50	62.0	4.0
50	66.0	-2.80	64.0	5.0
60	68.0	-3.00	66.0	5.5
70	70.0	-4.00	68.0	6.0
80	72.0	-4.50	70.0	7.0
90	72.0	-5.00	70.0	8.0
100	72.0	-6.00	70.0	10.0

Steam Press: 9.0 bar(g)
Stack O₂: 4.10 %
Firing Rate: 4.5 %
ID Press: -25.0 mmWC

This is read only page... Click on Master Table to change the settings

Master Table Back

19/12/2019 - 12:20:36
© Copyright Forbes Marshall Pvt Ltd E4KSolids

Master Table:

As per the fuel changes values in firing table needs to be redefined as per the fuel quality, so maximum 3 fuel configuration can be saved in databases.

By selecting Fuel1, Fuel 2 or Fuel 3 from the drop down provided at right top corner, respective settings will be copied in actual firing table.

The screenshot displays the EffiMAX software interface. At the top, it shows process parameters: ID Press: -25.0 mmWC, Stack O₂: 4.10 %, Steam Press: 9.0 bar(g), and Firing Rate: 4.5%. The main area contains three columns of data for Fuel 1, Fuel 2, and Fuel 3. Each column has a header row with 'ID FAN O/P', 'FD FAN O/P', 'ID Pr. SP', and 'O2 SP'. Below these are rows for firing rates from 0% to 100% in increments of 10%. A 'Fuel 1' dropdown menu is visible on the right side. At the bottom, there is a copyright notice for Forbes Marshall Pvt Ltd and a timestamp of 19/12/2019 - 12:21:27.

FIRING (%)	Fuel 1				Fuel 2				Fuel 3			
	ID FAN O/P	FD FAN O/P	ID Pr. SP	O2 SP	ID FAN O/P	FD FAN O/P	ID Pr. SP	O2 SP	ID FAN O/P	FD FAN O/P	ID Pr. SP	O2 SP
0	56.0	54.0	0.00	2.00	56.0	54.0	0.00	2.00	56.0	54.0	0.00	2.00
10	58.0	56.0	-0.50	2.40	58.0	56.0	-0.50	2.40	58.0	56.0	-0.50	2.40
20	60.0	58.0	-1.00	2.60	60.0	58.0	-1.00	2.60	60.0	58.0	-1.00	2.60
30	62.0	60.0	-2.00	3.00	62.0	60.0	-2.00	3.00	62.0	60.0	-2.00	3.00
40	64.0	62.0	-2.50	4.00	64.0	62.0	-2.50	4.00	64.0	62.0	-2.50	4.00
50	66.0	64.0	-2.80	5.00	66.0	64.0	-2.80	5.00	66.0	64.0	-2.80	5.00
60	68.0	66.0	-3.00	5.50	68.0	66.0	-3.00	5.50	68.0	66.0	-3.00	5.50
70	70.0	68.0	-4.00	6.00	70.0	68.0	-4.00	6.00	70.0	68.0	-4.00	6.00
80	72.0	70.0	-4.50	7.00	72.0	70.0	-4.50	7.00	72.0	70.0	-4.50	7.00
90	72.0	70.0	-5.00	8.00	72.0	70.0	-5.00	8.00	72.0	70.0	-5.00	8.00
100	72.0	70.0	-6.00	10.00	72.0	70.0	-6.00	10.00	72.0	70.0	-6.00	10.00

Operating EffiMAX

4.2.11 Feeder PID:

EffiMax

MIMIC | FLEXI | TRENDS | ALARMS | **SETTINGS**
Opr

O₂ Cal | **PID** | Boiler Data | Fuel Type | Blowdown | Limits | Range

System | Feeder | Product | Alarm Limits
Feeder

Feeder Control Output is overwritten by Manual Mode

Steam Pr. (bar): 9.02	Feeder Startup Time (sec): <input type="text" value="10"/>	P - Gain: <input type="text" value="1.0"/>
Steam Pr. Set Point: <input type="text" value="0.00"/>	Feeder Start O/P (%): <input type="text" value="5.0"/>	I - Time: <input type="text" value="5.0"/>
Feeder Table: <input type="button" value="Show"/>	Steam Pr. Max (bar): <input type="text" value="9.00"/>	D - Time: <input type="text" value="0.0"/>
Fuel / Feeder Table: <input type="button" value="Show"/>	Steam Pr. Min (bar): <input type="text" value="8.00"/>	Ramp Rate (%/sec): <input type="text" value="2"/>
Manual O/P (%): <input type="text" value="20.0"/>	Deadband (bar): <input type="text" value="0.50"/>	PID O/P Min (%): <input type="text" value="0.0"/>
Ramped Man. O/P (%): 20.0	Feeder Table PID Low (%): <input type="text" value="4.0"/>	PID O/P Max (%): <input type="text" value="100.0"/>
Feeder O/P (%): 18.0	Feeder Table PID High (%): <input type="text" value="45.0"/>	
	Mode (A/M): <input type="button" value="Auto"/>	

Actual Feeder OP as per Fuel/Feeder table configuration

Feeder1 O/P (%): 18.0
Feeder2 O/P (%): 0.0

© Copyright Forbes Marshall Pvt Ltd
19/12/2019 - 12:22:02

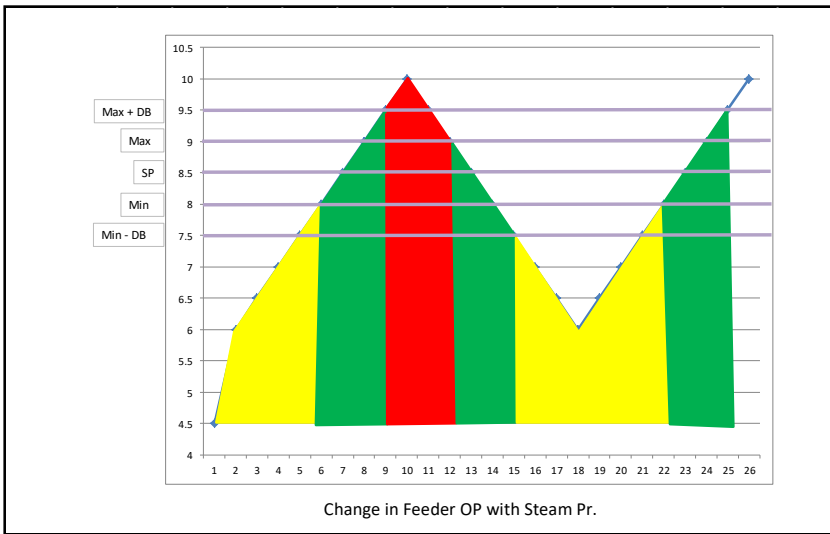

Feeder OP = Feeder High OP	Feeder OP = PID OP	Feeder OP = Feeder Low OP
----------------------------	--------------------	---------------------------

Steam Pr.: It displays the “Live” Steam Pressure value of the boiler.

Steam Pr. Set Point: This value defines the Steam Pr. Set point.

Feeder Table: This table is used to feed the Feeder motor VFD output corresponding to the PID output, so Feeder output is derived from these tables.

For each feeder user can define the multiplying factor in the range of 0 to 1, so that main OP is variably used for different feeders.

For ex. Feeder 1 Factor = 1, Feeder 2 Factor = 0.5

Feeder OP = 18%

Feeder 1 OP = 18%, Feeder 2 OP = 9%.

Manual OP: In manual mode user can set the Feeder output as required in Manual OP user entry field.

Feeder OP: Feeder OP % derived from the Feeder table based on the PID output.

Ramp Rate: It is the Value entered to set the number of steps in one second expressed in %/sec.

Feeder Startup Time: It is the time duration for the boiler to stabilize.

Feeder Start OP: Value entered in this field is used as Feeder OP for startup time duration. For ex.: In this case 5% Feeder OP for 10sec after boiler ON signal received.

Steam Pr. Max: This value defines maximum Steam pressure beyond which it can't be increase for safety purpose.

Steam Pr. Min: This value defines minimum Steam pressure beyond which it can't be reduced due to process requirement.

Operating EffiMAX

Feeder OP Low: Once the steam Pr. Shoots beyond Steam Pr. Max + Dead band, Feeder OP drops to Feeder OP Low, in order to reduce the steam pr.

Feeder OP High: Once the steam Pr. drops below Steam Pr. Min - Dead band, Feeder OP shoots to Feeder OP High, in order to cater the steam demand.

PID OP Min: This value is used to limit the PID output in Auto mode, so that output should not go below the minimum operating value.

PID OP Max: This value is used to limit the PID output in Auto mode, so that output should not go above the maximum operating value.

Feeder Table:

The screenshot displays the EffiMax control interface. At the top, there are navigation tabs: MIMIC, FLEXI, TRENDS, ALARMS, and SETTINGS. The main content area is titled 'Feeder Table' and contains a table with the following columns: PID O/P (%), Feeder O/P (%), Feeder No., and Feed Ratio/Feeder (0 to 1). The table has 11 rows, with the first row having a PID O/P (%) of 0 and a Feeder O/P (%) of 14.0. The second row has a PID O/P (%) of 10 and a Feeder O/P (%) of 16.0. The third row has a PID O/P (%) of 20 and a Feeder O/P (%) of 18.0. The fourth row has a PID O/P (%) of 30 and a Feeder O/P (%) of 20.0. The fifth row has a PID O/P (%) of 40 and a Feeder O/P (%) of 22.0. The sixth row has a PID O/P (%) of 50 and a Feeder O/P (%) of 24.0. The seventh row has a PID O/P (%) of 60 and a Feeder O/P (%) of 26.0. The eighth row has a PID O/P (%) of 70 and a Feeder O/P (%) of 30.0. The ninth row has a PID O/P (%) of 80 and a Feeder O/P (%) of 35.0. The tenth row has a PID O/P (%) of 90 and a Feeder O/P (%) of 40.0. The eleventh row has a PID O/P (%) of 100 and a Feeder O/P (%) of 45.0. To the right of the table, there are two input fields for 'Feeder No.' and 'Feed Ratio/Feeder (0 to 1)'. The first field contains '1.' and the second field contains '1.00'. Below the table, there is a red text warning: 'This is read only page... Click on Master Table to change the settings'. At the bottom right, there are two buttons: 'Master Table' and 'Back'. The bottom status bar shows the date and time '19/12/2019 - 12:22:23' and the text '© Copyright Forbes Marshall Pvt Ltd' and 'E4KSolids'.

PID O/P (%)	Feeder O/P (%)	Feeder No.	Feed Ratio/Feeder (0 to 1)
0	14.0	1.	1.00
10	16.0	2.	0.00
20	18.0		
30	20.0		
40	22.0		
50	24.0		
60	26.0		
70	30.0		
80	35.0		
90	40.0		
100	45.0		

Feed ratio/feeder is user settable (0 to 1.0), based on this value respective feeder OP is calculated.

For ex.:

Feed ratio for Feeder 1: 1

Feed ratio for Feeder2: 0.75

Feed ratio for Feeder2: 0.5

Feeder OP (%): 18.0.

So based on the ratio,

$$\begin{aligned}\text{Feeder 1 OP} &= \text{Feed ratio for Feeder 1} * \text{Feeder OP (\%)} \\ &= 1 * 18 \\ &= 18\%\end{aligned}$$

$$\begin{aligned}\text{Feeder 2 OP} &= \text{Feed ratio for Feeder 2} * \text{Feeder OP (\%)} \\ &= 0.75 * 18 \\ &= 13.5\%\end{aligned}$$

$$\begin{aligned}\text{Feeder 3 OP} &= \text{Feed ratio for Feeder 3} * \text{Feeder OP (\%)} \\ &= 0.5 * 18 \\ &= 9\%\end{aligned}$$

This will help in modulating the flow of respective feeder Zones, to maintain the pressure and reduce un-brunt.

Operating EffiMAX

Feeder Master Table:

As per the fuel changes values in Feeder table needs to be redefined as per the fuel quality, so maximum 3 fuel configuration can be saved in databases.

By selecting Fuel1, Fuel 2 or Fuel 3 from the drop down provided at right top corner, respective settings will be copied in actual Feeder table.

The screenshot displays the EffiMax control interface. At the top, it shows system parameters: ID Press: -25.0 mmWC, Stack O₂: 4.10 %, Steam Press: 9.0 bar(g), and Firing Rate: 4.5%. The 'FORBES MARSHALL' logo is in the top right corner. Below these parameters is a table for configuring the Feeder Master Table. The table has four columns: 'PID O/P (%)', 'Fuel 1 Feeder O/P (%)', 'Fuel 2 Feeder O/P (%)', and 'Fuel 3 Feeder O/P (%)'. The 'Fuel 1' column is highlighted with a blue border. A dropdown menu on the right is set to 'Fuel 1'. A 'Back' button is located at the bottom right of the table area. At the bottom of the interface, there is a copyright notice: '© Copyright Forbes Marshall Pvt Ltd' and 'E4KSolids'. A status bar at the very bottom shows the date and time: '19/12/2019 - 12:22:44'.

PID O/P (%)	Fuel 1 Feeder O/P (%)	Fuel 2 Feeder O/P (%)	Fuel 3 Feeder O/P (%)
0	14.0	14.0	14.0
10	16.0	16.0	16.0
20	18.0	18.0	18.0
30	20.0	20.0	20.0
40	22.0	22.0	22.0
50	24.0	24.0	24.0
60	26.0	26.0	26.0
70	30.0	30.0	30.0
80	35.0	35.0	35.0
90	40.0	40.0	40.0
100	45.0	45.0	45.0

4.2.12 Drum Level:

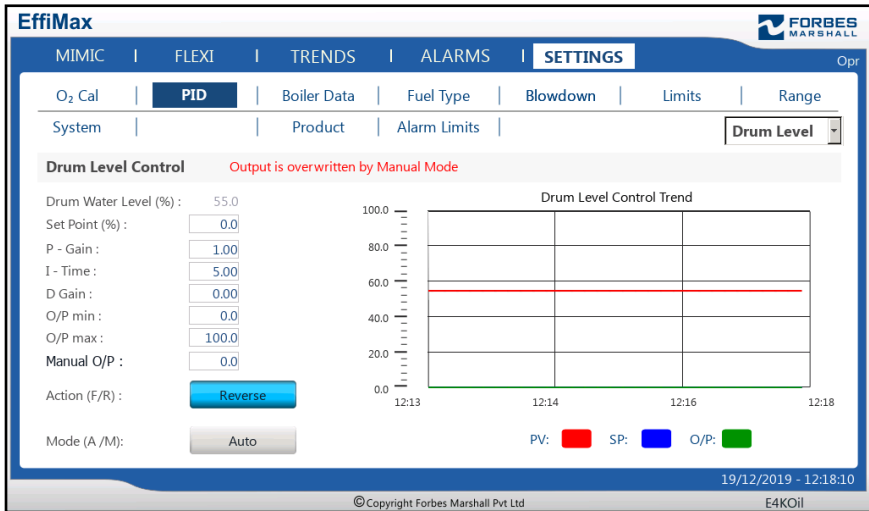

Drum Water Level: The Drum Water Level can be set 0-100%.

Setpoint: Selection of Set point is based on the SP mode selection. This is the value of O₂ set by user or derived from firing table for a particular firing rate.

Proportional Gain (P): Proportional value in the PID controller used to calculate the Output. This gain (P) should be tuned based on the response of the O₂ probe & the boiler combustion.

Repeats / Min (I): Integral Value in the PID controller used to calculate the Output. This indicates the rate of output value updation in a minute. For ex. If I is set as 10, then 60sec / 10 = 6. This means after every 6 sec output is re-calculated to control the damper / motor.

Derivative Gain(D): Derivative value in the PID controller used to calculate the Output.

Operating EffiMAX

PID OP Min: This value is used to limit the PID output in Auto mode, so that output should not go below the minimum operating value.

PID OP Max: This value is used to limit the PID output in Auto mode, so that output should not go above the maximum operating value.

Manual Output: In manual mode user can set the FD Fan output as required by user.

Action: Forward or Reverse action can set.

Mode: This helps to switch from auto to manual mode and vice versa. Manual Mode is used to bypass the control action and user can enter the Output as required from 0 – 100%.

4.2.13 Feeder Screen:

Feeder screen is used to calibrate the fuel flow of each feeder (max. 6 feeders). There are 14 steps in which RPM value & its corresponding fuel flow in kg/h should be entered. Software will linearize the fuel flow values between the two entries.

Drop down box on the left corner is used to navigate between different fuel feeder settings.



Red highlighted box is hidden button to navigate to fuel flow/rpm/hr settings.

RPM settings provided based on that customer can populate completed feeder tables.

To configure, first calculate the flow rate (kg/rpm/hr) for different fuels or different pulleys.

Enter those values in RPM Settings 1, 2 and 3.

Based on the live flow rate, select one of the option from drop down and click on "Populate Table" to reflect the changes in Feeder RPM settings.

- **SOP for Calculating Fuel Flow Rate (kg/rpm/hr):**

Feeder control through the VFD:

Note down the Motor Max rpm:rpm.

1. Consider Motor with max.1300 rpm @ 50Hz.
2. Set the VFD to 5Hz which corresponds to 130rpm. Of motor.
3. Make arrangement to collect the fuel which is feeding into the combustion chamber.
4. Run the motor at 130rpm (VFD: 5Hz) for 1 minute duration; simultaneously collect the fuel in container.
5. Repeat step No. 4 for 3 times.
6. Weight all the containers; make sure that container weight is neglected.
7. Take average of three samples for accurate reading.
8. This will give us amount of fuel @ 130rpm for 1 Minute.
9. Divide the Average weight by 130, this will give us Fuel/min for 1 rpm.
10. Now to calculate fuel on hourly basis, multiply the result of step No. 9 by 60.

Example:

1. Motor Max rpm: 1300 rpm
2. Measure the weight of container = 1 Kg
3. Set the VFD at 5Hz (i.e. 130rpm) run for 1 minute duration & collect 3 fuel samples.
 - i. Weight of Sample 1: 4.1kg
 - ii. Weight of Sample 2: 4.3kg
 - iii. Weight of Sample 2: 4.2kg
4. Take average of three samples: 4.2kg
5. Subtract container weight: $4.2 - 1 = 3.2\text{kg}$

6. Calculations:

- 130 rpm = 3.2 kg (For 1 minute duration)
- 1 rpm = 3.2/130 = 0.025 kg (For 1 minute duration)**

7. To calculate kg/hr for 1 rpm:

- **1 rpm = 0.025*60 = 1.5 kg/hr.**

8. With the help of this populate the Feeder table for 0 to 1300rpm.

100rpm = 1.5*100 = 150 kg/hr.

.
.

1300rpm = 1.5*1300 = 1950 kg/hr.

So for this case RPM setting 1 is 1.5 kg/rpm/hr, so change accordingly in RPM settings and click on Populate Table to reflect in RPM vs Flow Rate Table.

Provision for 3 RPM settings are provided to cater the condition of different fuel types available at site, as fuel changes and its flow rate per rpm also changes. So select respective RPM setting as per fuel used.

The screenshot shows the EffiMax software interface with three tables for Setting 1, Setting 2, and Setting 3. Each table has columns for RPM and Flow Rate. The Flow Rate values are 0.0, 1.0, 2.0, 3.0 for RPM values 0, 101, 201, 301, 401, 501, 601, 701, 801, 901, 1001, 1101, 1201, 1301. The interface also includes a dropdown for 'RPM Setting 1', input fields for 'RPM Setting 1: 1.00 kg/rpm', 'RPM Setting 2: 2.00 kg/rpm', and 'RPM Setting 3: 3.00 kg/rpm', a 'Populate Table' button, and a 'Back' button. A red warning message states: 'This is read only page...selected RPM settings will reflect in all 6 Feeder table on Populate table click'. The footer includes '© Copyright Forbes Marshall Pvt Ltd' and 'E4KSolids'.

4.2.14 Product Screen:

This screen sets the type of effiMAX variant, Input steam flow type, & many other crucial Product configurations as shown below:

EffiMax

MIMIC | FLEXI | TRENDS | ALARMS | **SETTINGS** | Opr

O₂ Cal | PID | Boiler Data | Fuel Type | Blowdown | Limits | Range

System | Feeder | **Product** | Alarm Limits

Software Version 1.0.0

Product Name	EffiMax 4000	No. of Feeders	1
Fuel Variant	Solids		
Efficiency Calculation	GCV		
Efficiency Type	Indirect	TDS Sensor Type	BBCS
Boiler On / Off Signal Type	Fuel Flow Cutoff	Input TDS Signal Type	Resistance
Density Calculation Using	Steam Temp.	TDS Measurement Type	Purge Mode
Input Steam Flow Type	Mass	TDS Resistance Range	10 to 400
Steam Flow Unit	Kg/h	Drum Level Control	Yes
Input O ₂ Signal Type	mA	Flexi Input	Yes
No of FD Fans	1	No of Flexi Inputs	4

Flexi Parameter Settings | Restore to Default | Next

31/12/2019 - 13:41:47
© Copyright Forbes Marshall Pvt Ltd | E4KSolids

- **Flexi Parameters Settings:**

This screen is to configure input name, type and unit of the additional parameters.

Parameter Name: To configure the name of parameter, just enter blank field under Flexi parameter, keypad will pop-up to enter the name of parameter.

Parameter Type: Depending on the averaging or totalization requirement, select 'Avg.' or 'Total' option.

Units: Respective parameters unit need to be entered through pop-up keyboard.

Enable: Once check box is selected, respective parameter and its total value will be displayed on Flexi parameters page.

The screenshot shows the 'SETTINGS' tab in the 'ALARMS' section. The 'Product' sub-tab is active, displaying a table for configuring alarm limits. The table has columns for System, Feeder, Product, and Alarm Limits. Each row represents a parameter with its analog input, flexi parameter name, average/total calculation, unit, and an enable checkbox.

System	Feeder	Product	Alarm Limits
A/1 1	Steam Flow 1	TTL	kg/h <input checked="" type="checkbox"/>
	Steam Total 1		kg
A/1 2	SPM	AVG	mg/Nm ³ <input checked="" type="checkbox"/>
A/1 3	Feedwater Hardness	AVG	ppm <input checked="" type="checkbox"/>
A/1 4	Feedwater Flow	TTL	kg/h <input checked="" type="checkbox"/>
	Feedwater Total		kg

31/12/2019 - 13:43:29
© Copyright Forbes Marshall Pvt Ltd E4KSolids

4.2.15 Alarms Screen:

This page is used to set the alarm levels for the parameters configured in the effiMAX. Parameter Name is mentioned and user is supposed to enter Low alarm value below which alarm will be generated of that parameter. Also, enter High alarm value above which alarm will be generated.

The screenshot shows the 'ALARM LIMITS' sub-tab in the 'SETTINGS' section. It displays a table with columns for Parameter, Low Enable, Low Setpoint, High Enable, High Setpoint, Hysteresis, and Actual Value. All 'Low Enable' and 'High Enable' checkboxes are checked.

Parameter	Low Enable	Low Setpoint	High Enable	High Setpoint	Hysteresis	Actual Value
Stack Temp.	<input checked="" type="checkbox"/>	120.0	<input checked="" type="checkbox"/>	300.0	0.0	250.0
Feed Water Temp.	<input checked="" type="checkbox"/>	25.0	<input checked="" type="checkbox"/>	120.0	0.0	58.0
O ₂ Heater Temp.	<input checked="" type="checkbox"/>	150.0	<input checked="" type="checkbox"/>	850.0	0.0	798.0
Steam Temp.	<input checked="" type="checkbox"/>	150.0	<input checked="" type="checkbox"/>	250.0	0.0	180.0
Ambient Temp.	<input checked="" type="checkbox"/>	20.0	<input checked="" type="checkbox"/>	60.0	0.0	26.0
Blowdown Temp.	<input checked="" type="checkbox"/>	110.0	<input checked="" type="checkbox"/>	240.0	0.0	180.0
Steam Pr.	<input checked="" type="checkbox"/>	6.0	<input checked="" type="checkbox"/>	15.0	0.0	9.02

Next
13/12/2019 - 12:05:05
© Copyright Forbes Marshall Pvt Ltd E4KSolids

SECTION 5: BLOWDOWN SYSTEM

5.1 Introduction

STANDALONE TDS MEASUREMENT SYSTEM:

- The **standalone TDS measurement system** measures the total dissolved solids of the boiler water & helps the user to keep the records of the same. This sensor is installed on the blowdown line.
- For installation of TDS sensor please refer 'Installation diagram of TDS sensor' in Section 11.

BBCS:

The **Boiler Blowdown Control System (BBCS)** system is designed to maintain boiler water total dissolved solids (TDS) within a band as indicated by the boiler manufacturer, water treatment specialists or in standards for TDS control.

- It maintains the TDS of drum water specified by the boiler attendant.

5.2 Operating Principle

The BBCS system periodically opens the Blowdown valve automatically and purges the water.

The BBCS sensor, mounted in the sensor chamber, measures the TDS of the Blowdown water.

This measured value is compared with the user-fed set point on the display in a following manner:

1. If the measured value is lower than the set point, the Blowdown valve closes at the end of the purge time and remains closed until the next purge.
2. If the measured value is higher than the set point, the controller continues the Blowdown cycle until the measured value drops below the set point.

Typical Operations:

- ❖ **Measured TDS lower than the set point**

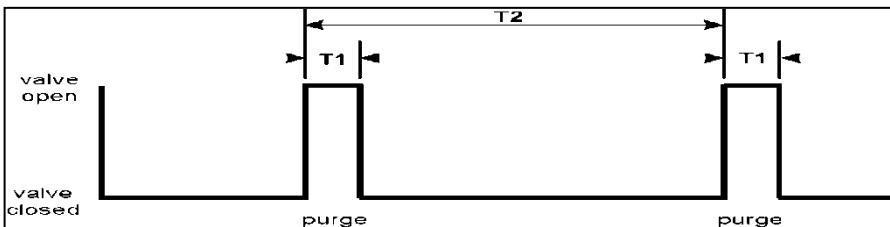

Fig. 6 Typical Operation 1

T1: Initial purge time: Standard setting is 10 seconds. It can be varied between 1 to 60 seconds in the computation unit.

T2: Time between purges: Default setting is 30 minutes & can be programmed on the analyzer as per required in the application.

T3: Time between blowdown: Standard setting is 20 seconds. This is useful in cases where the expected blowdown is less than 800 kg/h. It will make the blowdown cycles intermittent.

T4: Blowdown time: Default setting is 10 seconds. It can be varied from 1 second to up to 60 seconds on the computation unit.

Blowdown System

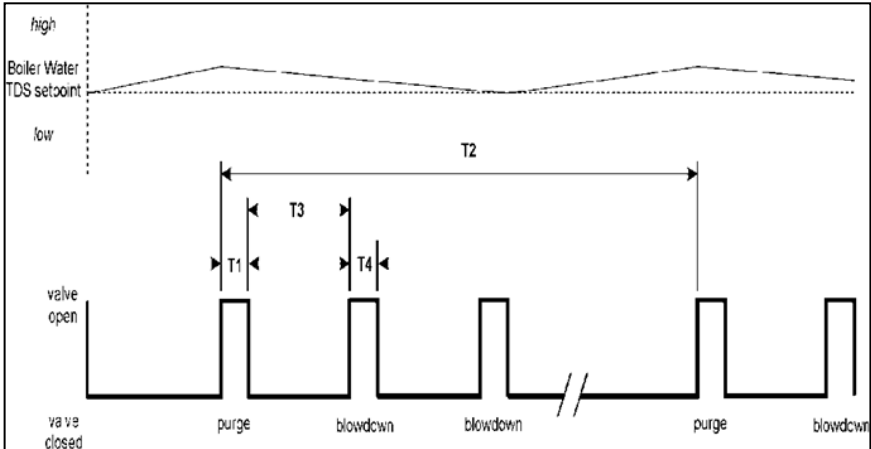

Fig. 7 Typical Operation 2

❖ TDS being controlled near set point:

A conductivity sensor measures the boiler water TDS during the purge cycle. The resistance of this sensor changes with the change in conductivity. This is sensed by the EffiMAX Signal conditioning unit and the actual TDS value is computed and displayed by the Display unit. This is then compared with the set-point in the blowdown controller and action is taken accordingly.

❖ Features and Benefits:

- Reduced operating costs (less feed water consumption; chemical treatment and higher heating efficiency)
 - Reduced maintenance and repair costs (minimized carryover and deposits)
 - Cleaner and more efficient steam
 - Minimize energy loss from boiler blowdown
 - Compact and complete boiler blowdown control solution
 - High quality components requiring low maintenance

5.3 Assembly of the system

A typical installation is shown in the Boiler Blowdown Control System assembly drawing below. Assemble the system using the gaskets supplied between flanges. Note the following points.

BBCS Assembly diagram:

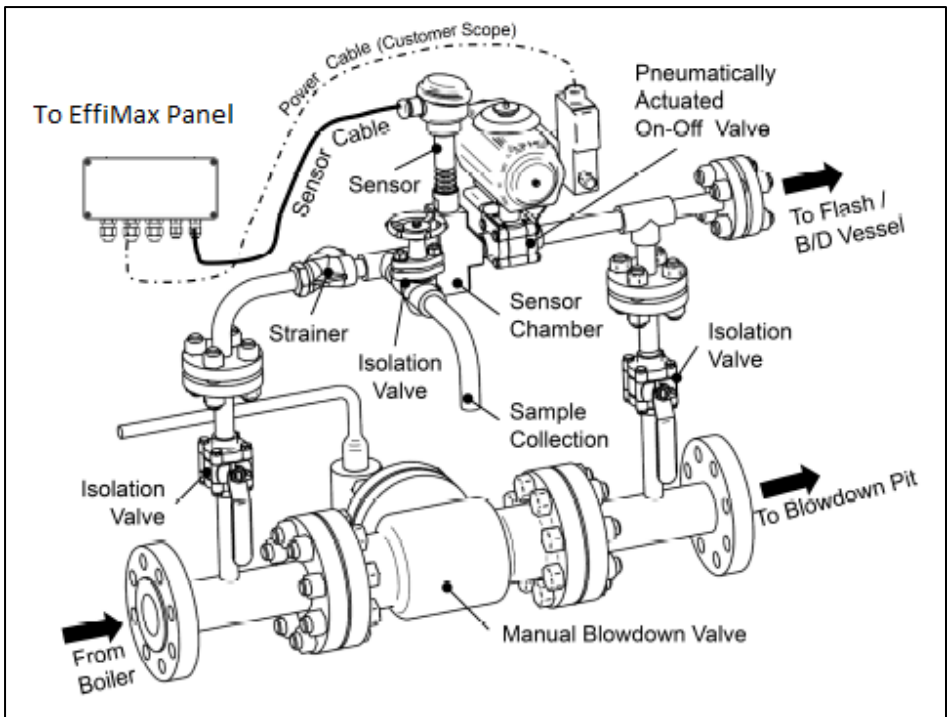

Fig. 8 BBCS Assembly details

Blowdown System

❖ Core components of BBCS

- High Temperature Conductivity Sensor (HTCS) with built-in Temperature Sensor.(Cell Constant K=1)
- Sensor Chamber
- 4-Core Shielded Cable for BBCS Sensor
- Boiler Blowdown Control Piping

System comprises of following –

1. Isolation Valves,
2. 'Y' Strainer,
3. Sample Collection Point,
4. Sensor Chamber,
5. Pneumatically Operated On-off Blowdown Valve
6. Manual Blowdown Valve

❖ Pressure and Temperature Limits:

1. Mechanical:

- Maximum Operating Pressure: 31 Kg/cm²(g)
- Maximum Operating Temperature: 238 °C
- Cold Hydraulic Test Pressure: 47 kg/cm²(g)
- Minimum Operating Temperature: 0 °C
- Instrument Air Supply: 4 to 6 Kg/cm²(g)

2. Measurement:

- TDS Range: 500 to 10000 ppm, Resolution: 10 ppm
- Temperature Range: 0 to 250 °C, Resolution: 0.1 °C

❖ **Boiler Bottom Blowdown Line Connections**

All connecting pipe work should always be free from external stresses & adequately supported.

Forbes Marshall BBCS unit must not be operated above the maximum pressure & temperature of boiler blowdown water indicated on system general arrangement drawing / product nameplate.

Connect the Inlet & Outlet boiler blowdown line as indicated in respective general arrangement drawing for to BBCS unit.

❖ **BBCS Sensor Installation**

Fit the sensor chamber in a horizontal pipeline with suitable isolation valves to facilitate inspection/cleaning of the sensors. Process flow must be in the direction of arrow marked on sensor chamber. **The sensor must be fitted in vertical direction with sensor head upwards.** The sensor is supplied with a gasket for sealing between sensor & sensor chamber.

Do not install the sensor outdoors without additional weather protection

Do not install the sensor in inverted/horizontal position

Fit the sensor to the sensor chamber by gripping it across flat provided on sensor for spanner only. Do not apply torque to sensor aluminium head or extension piece with cooling fins to fit sensor to sensor chamber.

Ensure that sensor cable is not exposed to a temperature greater than 120°C

❖ **Air Supply**

Connect instrument air supply at 4 to 6 kg/cm²(g) to Air Filter Regulator mounted on On-off blowdown valve.

Blowdown System

❖ Signal Cable Connections:

It is mandatory to use Forbes Marshall BBCS Sensor Cable only, supplied along with BBCS unit to connect the BBCS Sensor to EffiMax.

Length of BBCS Sensor cable is limited to 5 meters. In special case it can be 30 meters max. Maintain distance between the BBCS sensor & EffiMax accordingly.

Forbes Marshall BBCS sensor cable available in Length 5 meter as Standard & 30 meter as optional. Sensor cable length must be specified in Purchase order.

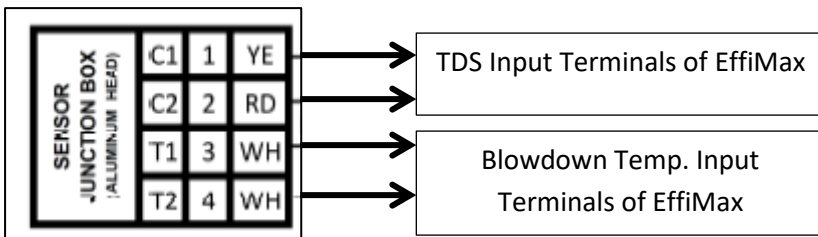

YE: Yellow

RD: Red

WH: White

C1, C2: Conductivity Input

T1, T2: Blowdown Temperature Input.

5.4 Commissioning the System



Ensure that the downstream of blowdown valve is fully open.

After mechanical and electrical installation, the system must be commissioned as follows:

1) Testing for leaks:

Open the two ball valves and with the boiler under pressure open the blowdown valve for the purge time T1 by briefly pressing the “purge” button on the controller.

Blowdown should be discharged to the blowdown vessel for approximately 30 seconds (the standard setting). Check that the pipe-work becomes hot (indicating flow) and that there are no leaks.

2) Setting the purge time T1:

For most small boilers the standard purge time of 30 seconds is sufficient to ensure that hot blowdown at boiler temperature reaches the sensor so that the controller can measure its true TDS.

Where there is rather long or large bore pipe-work upstream of the sensor, a longer purge time may be required.

The necessary purge time may be programmed through software (as shown below).

Starting with the blowdown pipe-work reasonably cold (e.g. after standing for at least 15 minutes) press and hold the “purge” button until the display reaches its highest steady reading. The time taken to reach the highest reading is the minimum required purge time.

If the required purge time is longer than 30 seconds, set the required purge time as was shown below. After adjustment the purge time can be checked by briefly pressing the “purge” button, when the blowdown valve will open for the set purge time. Make adjustments as necessary.

3) Setting the blowdown time T3:

For most process boilers, the standard time between blow-downs (T3) of 40 seconds is satisfactory. For very high blowdown rates, T3 may be set to zero so that blowdown is continuous. It is important that the required blowdown rate is not more than the maximum rate possible through the valve; otherwise the valve will remain open and still not be able to regulate TDS. The maximum blowdown rates at various boiler pressures are as follows:

Boiler Pressures	Blowdown rates (kg/h)	
	T3 = 20 seconds	T3 = 0 seconds
5.5	333	1000
10.5	900	2700
17.5	1233	3700
21.5	1500	4500
31.5	1900	5500

4) Setting the time between purges (T2):

Time T2 should be set as specified by the boiler manufacturer or as found out by experience of the boiler operator. EffiMAX uses a default setting of 30 minutes.

5) Setting the blowdown time (T4):

This should be set on the basis of the operating pressure of the boiler and on the distance of the sensor from the boiler. The default value of 20 seconds is generally sufficient and need not be disturbed. It is important to remember that a larger T4 will mean more water flowing out of the boiler. This can result in triggering the low water alarm of the boiler.

5.5 Trouble Shooting

In case of problems, refer to the following points:

1) The boiler water TDS continue to rise above the set point although the 'Purge' message is flashing on the controller and blowdown is being discharged through the blowdown valve:

The controller is operating correctly, but the blowdown valve is passing insufficient flow.

The valve or pipe work may be partially blocked, or it may be necessary to set the time between blowdown (T3) to zero).

Where a heat recovery system is installed, ensure that the blowdown is being properly discharged, and is not contaminating the feed-water system. Increasing boiler water TDS may also be caused by condensate or feed-water contamination from any source.

2) The boiler water TDS continues to fall although the 'Blowdown Cycle' message never flashes on the controller:

Check that the blowdown valve shuts off tight and ensure that the purge time (T1) is set as low as possible. If the boiler water TDS continues to fall ensure that other blow down are not excessive. Examples could be a leaking bottom blow down valve or leaking level control chamber drain valves.

3) The blowdown valve does not operate even though the 'Blowdown Cycle' message flashes on the controller display:

This may be caused by a blocked pneumatic line to the pneumatic Blowdown Valve. Often, the air-lines get clogged by dirt or fluid.

A globe valve, strainer and pressure regulator in the air line are recommended.

SECTION 6: TEMPERATURE TRANSMITTER

6.1 Introduction

The **Stack, Steam, Feed-Water and Ambient Air Temperature Transmitters** are two wire loop powered temperature transmitters. The primary sensing element is an RTD, PT-100. These sensors have built-in transmitters located on the head of the instruments. This are powered from the EffiMAX Signal Conditioning unit (24 V DC) and provides an output of 4-20 mA.

After installing the temperature transmitters, check the reading on the display unit. This should be between $\pm 2^{\circ}$ C of temperature measured at that location with any other calibrated and certified temperature-measuring instruments such as a thermometer.

These transmitters have different output ranges. These ranges are programmed into the Electronics unit from the factory. In case where the temperature transmitters are procured locally make sure the ranges are same as mentioned in the specifications.

SECTION 7: MAINTENANCE SCHEDULE

Given below is a matrix of the maintenance that needs to be carried out on each sub-system. Please ensure that maintenance is carried out regularly and as per the instructions given below it.

	Weekly	Monthly	Annual
TDS System	Yes		Yes
Oxypro		Yes	
Temperature transmitters		Yes	

7.1 TDS System

- Weekly**

Ensure following things are inline during maintenance schedule:

- i. Pneumatic (air) line is pressurized.
- ii. On purging, pneumatic valve is powered with 230VAC.
- iii. Blowdown water is actually discharged when the purge button is pressed (e.g. by temperature or sound)
- iv. Strainer is cleaned & strainer mesh is in good condition.
- v. Upstream & downstream of blowdown skid isolation valves are fully open.
- vi. There is no scaling on the sensor tip to have accurate sensing.
- vii. Connection between field cables & sensor cables are intact.

Measure the boiler water TDS and perform the calibration.

Maintenance Schedule

- **Annually**

Isolate the system by turning off Isolation valves (or when the boiler is empty) & remove the sensor from the sensor chamber. Clean the sensor tip and the insulator with a bristle brush or cloth. If damaged, replace the sensor (with the joint gasket). Internally clean and check sensor chamber, blowdown valve and check valve. If damaged, replace these items.

7.2 Oxypro

- Switch off the unit.
- Remove the unit from the stack.
- Clean the filter on its tip gently.
- Perform 20.9 % calibration on monthly basis.

7.3 Temperature Transmitter

- Remove the Temperature Transmitter from the field & have visual inspection of RTD stem & thermowell.
- Ensure that field cable running should not be in contact with hot surfaces like steam line or flue gas ducts.
- Compare the current displayed temperature value with corresponding resistance value of RTD using a standard RTD Resistance chart.

Procedure for on-site cross checking of RTD Temperature Sensor:

- i. Remove the TT from the process.
- ii. Ensure that there is no any physical damage to the TT.
- iii. Remove the Red 1, Red 2 & white cable of RTD from Transmitter head.

- iv. Allow the temperature of TT settle down to Ambient temperature.
- v. Measure the resistance between any of Red & white cable.
- vi. At ambient temp. consider of 25 deg C,

$$\begin{aligned}R &= (\text{Temp} * 0.39) + 100 \\ &= (25*0.39) + 100 \\ &= 9.75 + 100 \\ &= 109.75 \text{ ohms}\end{aligned}$$

For resistance values refer the standard RTD chart.

So at ambient conditions cross check the resistance. If resistance is in Mega Ohms then it indicates the sensor is open OR if it is around 0 ohm then it indicates the sensor is short internally.

If there is any deviation, please perform the calibration as per the standard procedure or contact to concern person.

SECTION 8: SPARES LIST

The following is a list of recommended spares available from Forbes Marshall:

Item
ER CPU
ER AI Card
ER AO Card
ER DI Card
ER DO Card
Smart Card
PWM-RTD Card
EXOR 10 inch HMI
24Vdc Power Supply
AM Station
Isolators
I-V or V-I Converter
Signal Splitter
Thermowell
Stack Temp transmitter
Steam Temp transmitter
Feed water Temp transmitter
Ambient Temp transmitter
O2 Probe
Steam Flow Meter

SECTION 9: DO's & DON'Ts

1. Do make sure that all the wiring is protected from physical damage.



2. Do ensure that the blow down valve downstream is fully open.

3. Don't clean the TDS sensor with a wire brush or other abrasive methods.

4. Don't disconnect wiring without switching OFF the power supply.

5. Don't attempt to repair the PCB assembly.

6. Don't fit a needle valve in the air line.

7. Don't turn the calibration potentiometer unless informed to FM.

8. Don't make any transmitter connection without switching OFF unit.

9. Don't make V/I converter connections without switching OFF unit.

10. Don't short the transmitter inputs. It may cause analog input failure.

11. Do not touch transformer with Greasy/Oily/Dirty hands. Keep Touch screen in clean environment and wipe with clean cloth every day.

**SECTION 10:
LOG REPORT**

10.1 Data Logging Sheet

The report format given on the next page can be used for manually logging the readings of effiMAX, in case the data is not being logged on a PC.

SECTION 11: INSTALLATION DRAWINGS

Below are the details of the Installation of the individual sensors.

These diagrams indicate typical installation of the sensors. Actual installation can vary as per the customer's specific requirements.

To get the feel of installation please check the installation videos, these videos will help for proper installation of filed instruments.

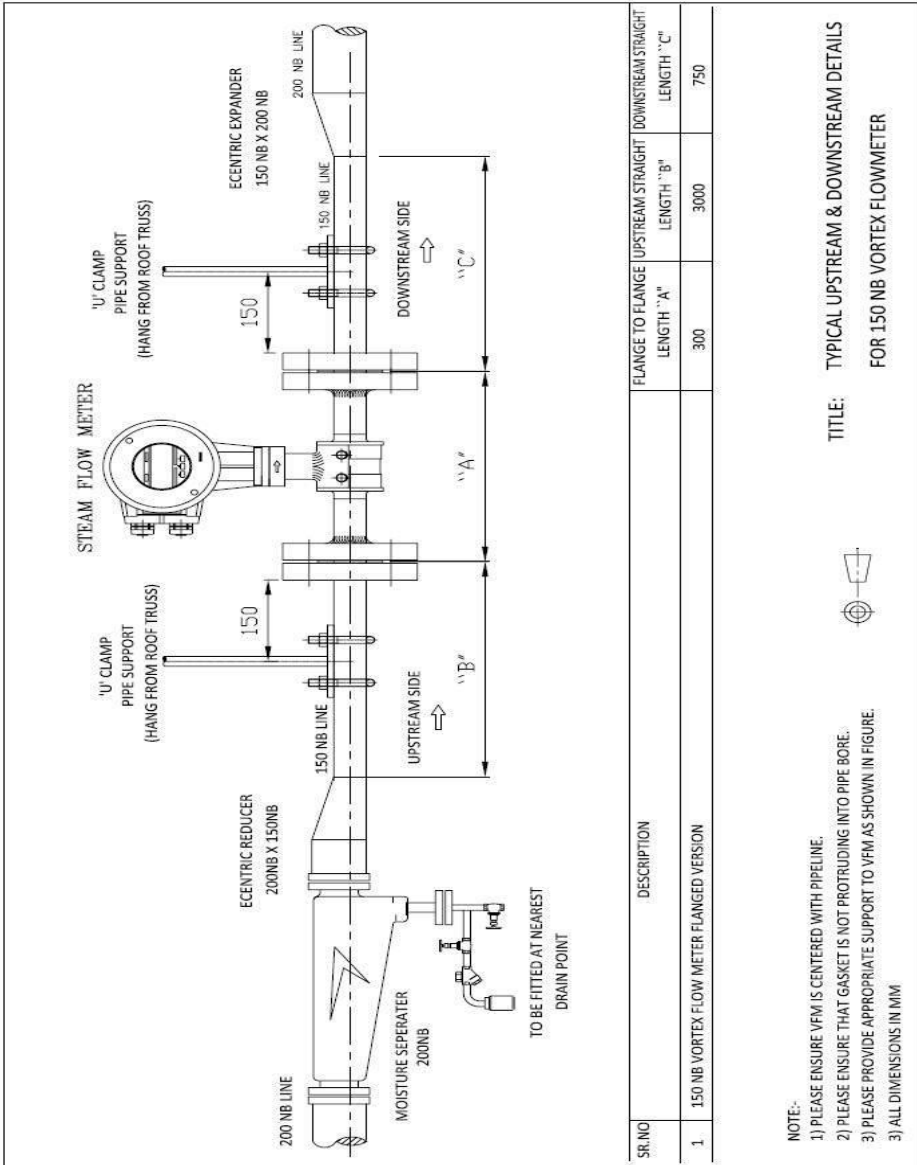
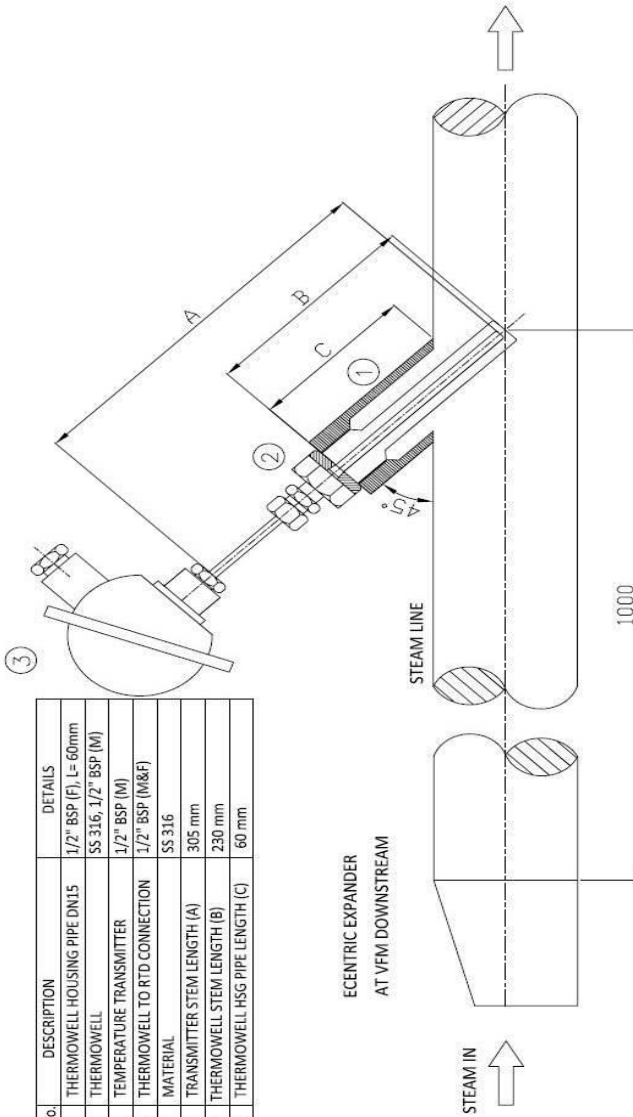

Fig. 9 Steam Flow Meter Installation diagram

SIZE	ϕ	$\Delta\phi$	SIZE	ϕ	$\Delta\phi$
DN (mm)	mm (inch)	mm (inch)	DN (inch)	mm (inch)	mm (inch)
10S	8.9 (0.35)	0.4 (0.016)	3/8"S	8.9 (0.35)	0.4 (0.016)
10	12.6 (0.50)	0.4 (0.016)	3/8"	12.6 (0.50)	0.4 (0.016)
15	14.9 (0.59)	0.4 (0.016)	1/2"	14.9 (0.59)	0.4 (0.016)
20	20.9 (0.82)	0.4 (0.016)	3/4"	20.9 (0.82)	0.4 (0.016)
25	28.5 (1.12)	0.4 (0.016)	1"	26.7 (1.05)	0.4 (0.016)
40	43.1 (1.70)	0.4 (0.016)	1 1/5"	40.9 (1.61)	0.4 (0.016)
50	54.5 (2.15)	0.6 (0.024)	2"	52.6 (2.07)	0.6 (0.024)
80	82.5 (3.25)	0.6 (0.024)	3"	78 (3.07)	0.6 (0.024)
100	107.1 (4.22)	0.6 (0.024)	4"	102.4 (4.03)	0.6 (0.024)
150	159.3 (6.27)	0.8 (0.031)	6"	154.2 (6.07)	0.8 (0.031)
200	206.5 (8.13)	1 (0.039)	8"	202.7 (7.98)	1 (0.039)

Steam Flow Meter Sizing Details



S.No.	DESCRIPTION	DETAILS
1	THERMOWELL HOUSING PIPE DN15	1/2" BSP (F), L= 60mm
2	THERMOWELL	SS 316, 1/2" BSP (M)
3	TEMPERATURE TRANSMITTER	1/2" BSP (M)
4	THERMOWELL TO RTD CONNECTION	1/2" BSP (M&F)
5	MATERIAL	SS 316
6	TRANSMITTER STEM LENGTH (A)	305 mm
7	THERMOWELL STEM LENGTH (B)	230 mm
8	THERMOWELL HSG PIPE LENGTH (C)	60 mm

TITLE: TYPICAL INSTALLATION DETAILS
FOR STEAM TEMPERATURE TRANSMITTER

NOTE:- ALL DIMENSIONS IN MM



Fig.10 Steam Temp. Transmitter Installation diagram

Installation Drawings

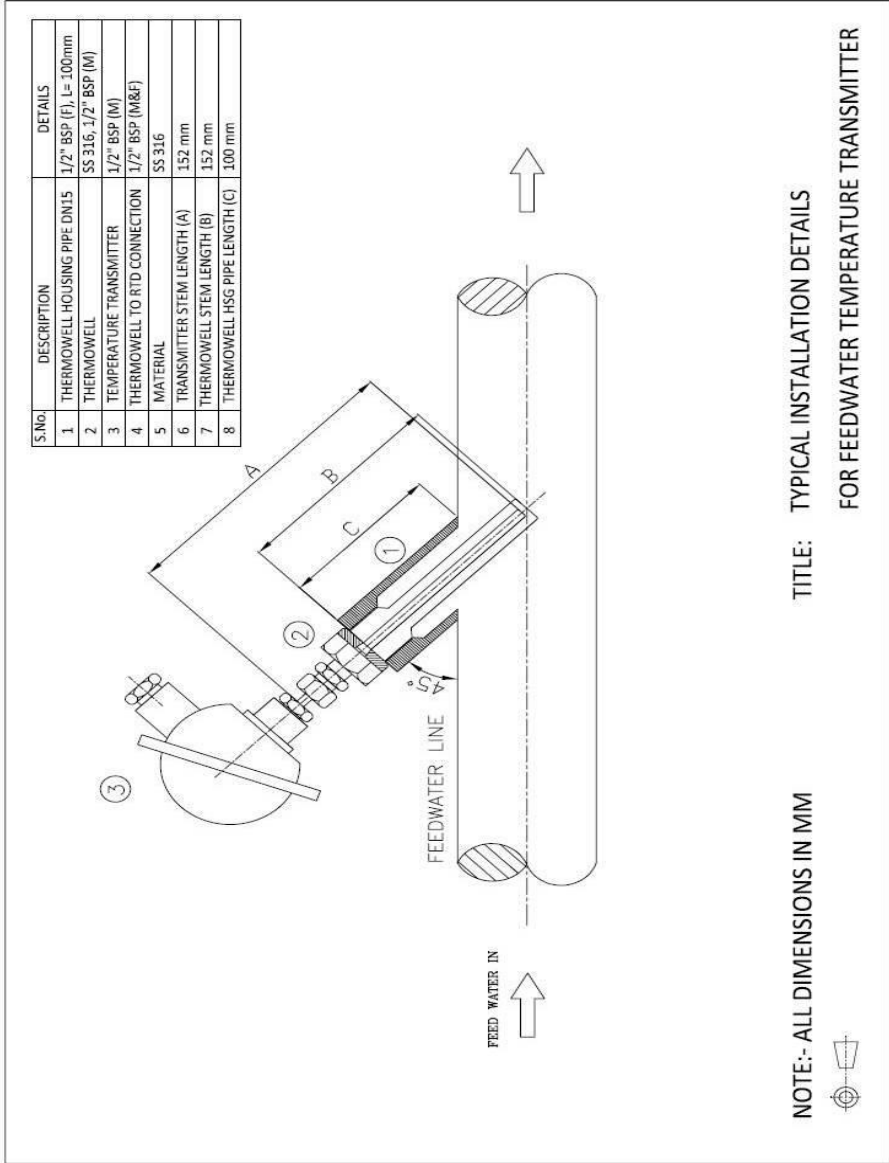
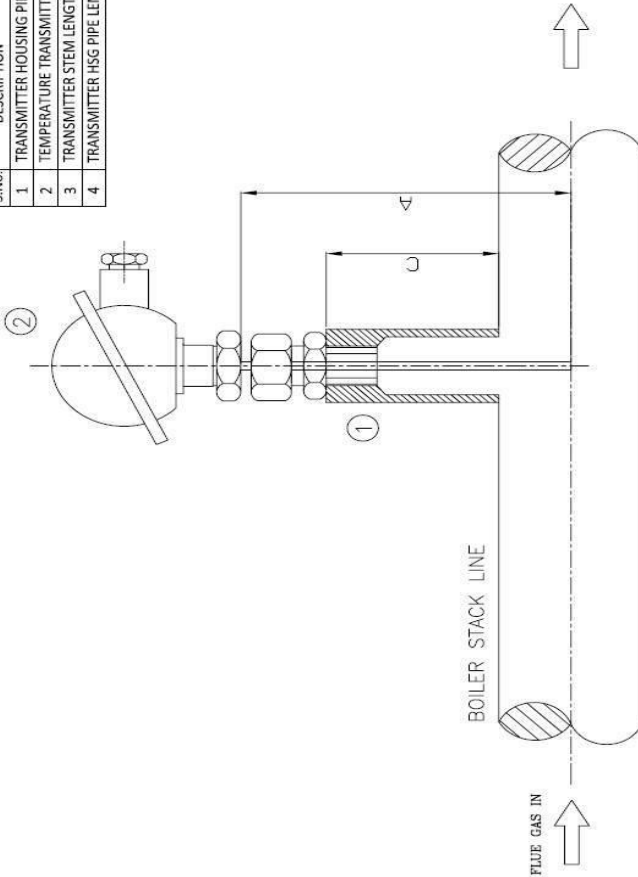

Fig.11 Feed water Temp. Transmitter Installation diagram

S.No.	DESCRIPTION	DETAILS
1	TRANSMITTER HOUSING PIPE DN15	1/2" BSP (F), L= 30mm
2	TEMPERATURE TRANSMITTER	1/2" BSP (M)
3	TRANSMITTER STEM LENGTH (A)	457 mm
4	TRANSMITTER HSG PIPE LENGTH (C)	30 mm



TITLE: TYPICAL INSTALLATION DETAILS
FOR STACK TEMPERATURE TRANSMITTER

NOTE:- ALL DIMENSIONS IN MM

Fig.12 Stack Temp. Transmitter Installation diagram

Installation Drawings

SR. NO.	DESCRIPTION	DETAILS	QTY.
1	PIPE	DN65, PN6, SCHEDULE 40, LENGTH (outside the duct wall)= 500- (Stack Dia./3mm Some part of the pipe will go inside the duct wall, so pipe length should be more than above calculated length	1
2	MOUNTING FLANGE	AS PER MOUNTING FLANGE DETAILS DRAWING	1
3	OXYGEN PROBE	STACK OXYGEN MEASUREMENT	1

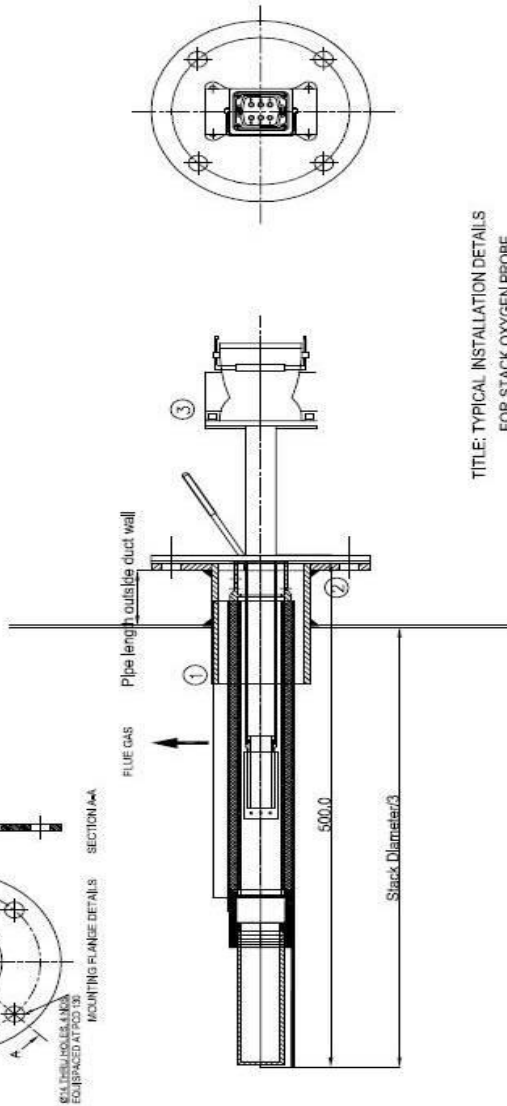
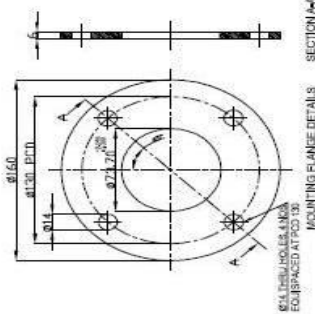

NOTE: ALL DIMENSIONS IN MM

Fig.13 Stack Oxygen Sensor Installation diagram

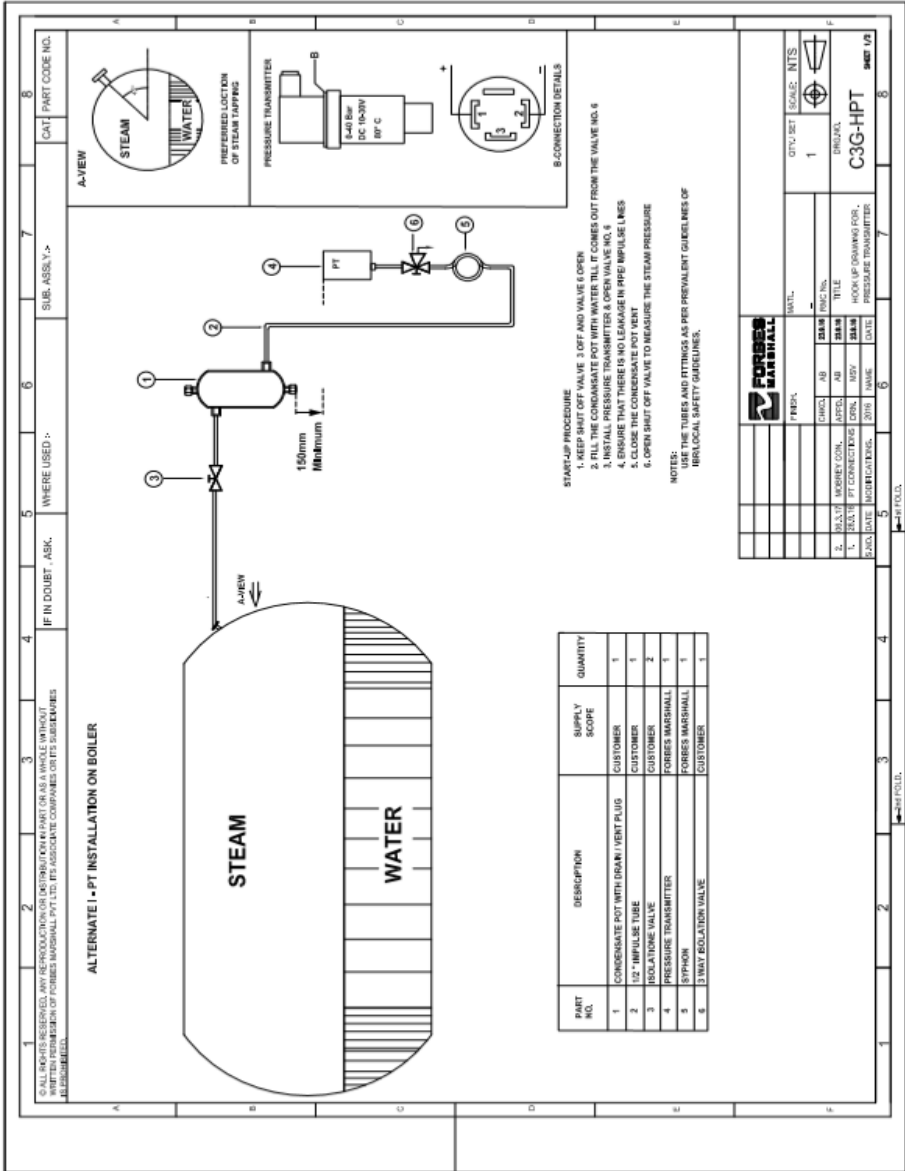

Fig.15 Steam Pressure Transmitter Installation diagram

Notes:



Forbes Marshall
Krohne Marshall
Forbes Marshall Arca

Codel International
Forbes Solar

Forbes Vyncke
Forbes Marshall Steam Systems

Opp 106th Milestone
Bombay Poona Road
Kasarwadi, Pune - 411 034, INDIA
Tel : 91(0)20-27145595, 39858555
Fax : 91(0)20-27147413
Email : seg@forbesmarshall.com, ccmidc@forbesmarshall.com

B-85, Phase II, Chakan Indl Area
Sawardari, Chakan, Tal, Khed
Dist. Pune - 410 501, INDIA
Tel : 91(0)2135-393400

A-34/35, MIDC H Block
Pimpri, Pune - 411 018, INDIA,
Tel : 91(0)20-27442020, 39851199
Fax : 91(0)20-27442040
CIN No.: U28996PN1985PTC037806
www.forbesmarshall.com

© All rights reserved. Any reproduction or distribution in part or as a whole without written permission of Forbes Marshall Pvt Ltd, its associate companies or its subsidiaries ("FM Group") is prohibited.

Information, designs or specifications in this document are subject to change without notice. Responsibility for suitability, selection, installation, use, operation or maintenance of the product(s) rests solely with the purchaser and/or user. The contents of this document are presented for informational purposes only. FM Group disclaims liabilities or losses that may be incurred as a consequence of the use of this information.