

CountAIR

A Complete Solution for Monitoring Compressed Air Networks

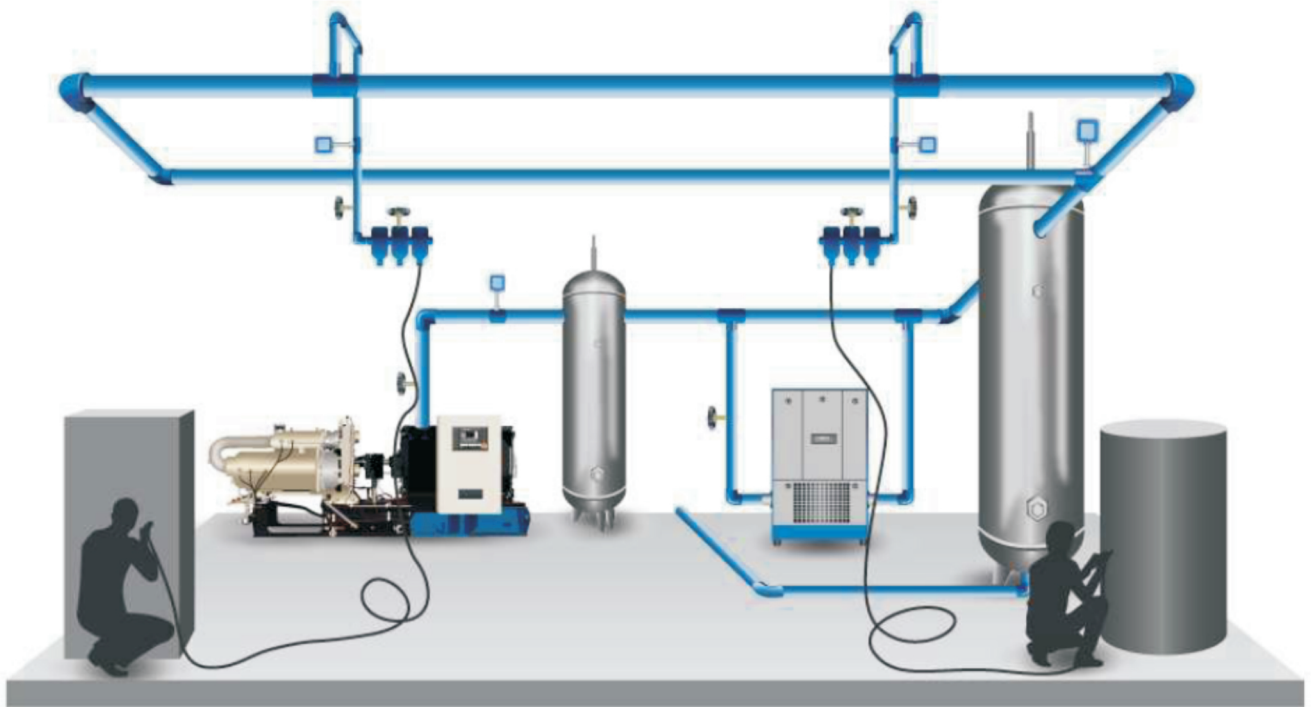

Leaving the compressed air network unmonitored opens the door to inefficiency. Monitoring the network, from generation (FAD) to consumption is the first step to the path of energy savings.

Most compressed air networks tend to be mismatched – generation often outstrips the demand, and most utility managers provide air to processes based on an approximate or intuitive guess about the requirements. This is chiefly due to the lack of monitoring of the compressed air network. As a result, the compressed air system faces issues such as:

Excess compressed air generation

Excess pressurisation

Unmonitored changes in consumption patterns

High operational cost

Why Choose CountAIR?

Stay informed on compressor efficiencies, individual unit demand and leakages in the compressed air network

With the CountAIR you will always be aware of

Real-time specific compressor and machine data

Deviations of any machine or area from its trend line and rated consumption

An overall plant demand overview

All necessary information to save and control unaccounted losses in the system

Presence of leakages in your distribution lines

What CountAIR offers

Historical trends of each area/unit with graphs

Benchmarks for the system

Alarms when demand spikes in any area

Real-time, user selectable alarms

Intelligent or user-defined benchmarks for generation and consumption

Real-time compressor efficiency monitoring

Linking with existing DCS or SCADA

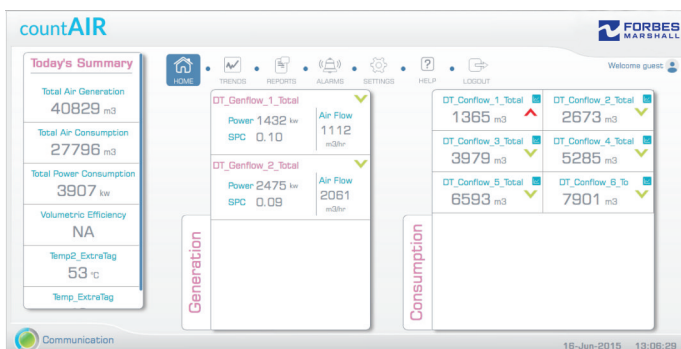
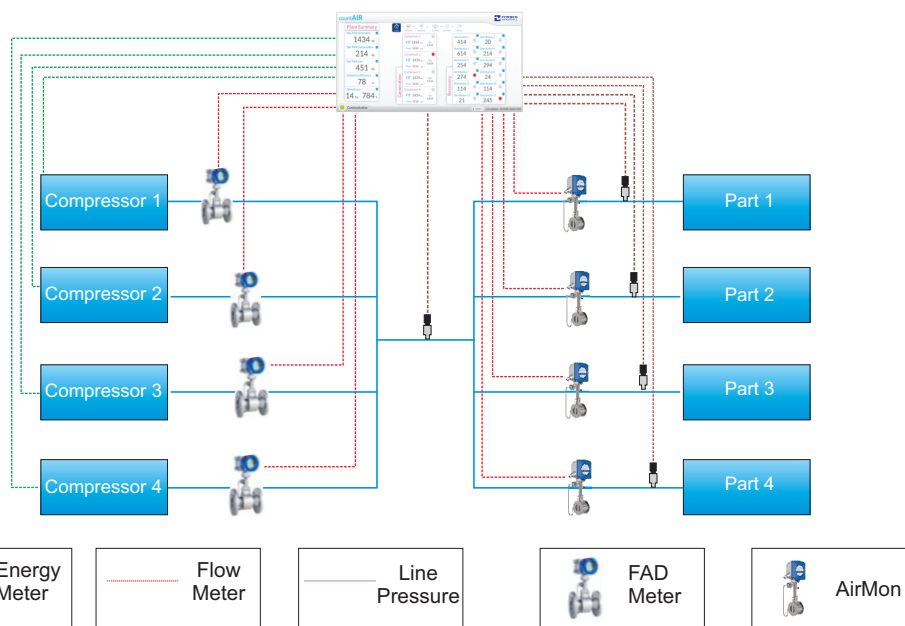

Forbes Marshall
Krohne Marshall
Forbes Marshall Arca
Codel International
Forbes Solar
Forbes Vyncke
Forbes Marshall Steam Systems

Opp 106th Milestone
Bombay Poona Road
Kasarwadi, Pune - 411 034. INDIA
Tel : 91(0)20-27145595, 39858555
Fax : 91(0)20-27147413

Email : airaudits@forbesmarshall.com, ccmidc@forbesmarshall.com

© All rights reserved. Any reproduction or distribution in part or as a whole without written permission of Forbes Marshall Pvt Ltd, its associate companies or its subsidiaries ("FM Group") is prohibited.
Information, designs or specifications in this document are subject to change without notice. Responsibility for suitability, selection, installation, use, operation or maintenance of the product(s) rests solely with the purchaser and/or user. The contents of this document are presented for informational purposes only. FM Group disclaims liabilities or losses that may be incurred as a consequence of the use of this information.

B-85, Phase II, Chakan Indl Area
Sawardari, Chakan, Tal. Khed
Dist. Pune - 410 501. INDIA
Tel : 91(0)2135-393400

A-34/35, MIDC H Block
Pimpri, Pune - 411 018. INDIA.
Tel : 91(0)20-27442020, 39851199
Fax : 91(0)20-27442040

CIN No. : U28996PN1985PTC037806
www.forbesmarshall.com