

# Steam and Water Analysis Systems (SWAS)

An Exclusive Range for Sample Conditioning and Analysis Systems



# Steam and Water Analysis Systems (SWAS)

In power plants, high pressure boilers and steam turbines are under constant attack from erosive and corrosive elements such as silica, sodium, dissolved oxygen, calcium, chloride and phosphates. Without accurate measurement and monitoring, the plant may suffer heavy mechanical damage that can be caused due to imbalance of turbines, reduced efficiency, deposition on turbine blades, corrosion of steam pipe work and so on.

Our Steam and Water Analysis System (SWAS) is designed to keep you in power. SWAS assures the safety of your boiler and turbines, by taking and analysing up to a dozen samples from all the water and steam circuits. In today's supercritical power plants, sample conditions as high as 600 Degree C and 300 bar are quite common. The Forbes Marshall SWAS can easily take care of these samples. To protect your equipment, our SWAS works in two stages:

Sample conditioning

Sample analysis

## Sample Conditioning

The first section of any SWAS is the sample conditioning section or the wet panel.

Here the sample is first cooled in sample coolers, de-pressurised in pressure regulators and then fed to various analyzers while keeping the flow characteristic constant by means of a back pressure regulating device. There are several safety equipment provided in wet panels, so that the operators feel safe while working with these systems.

## Open Frame-Free Standing Wet Rack

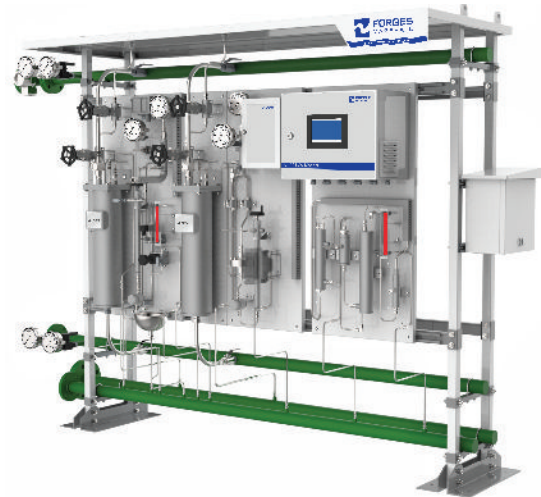

## Enclosed Type Wet Panel



## SWAS in container



# Schematic Diagram for Sampling System

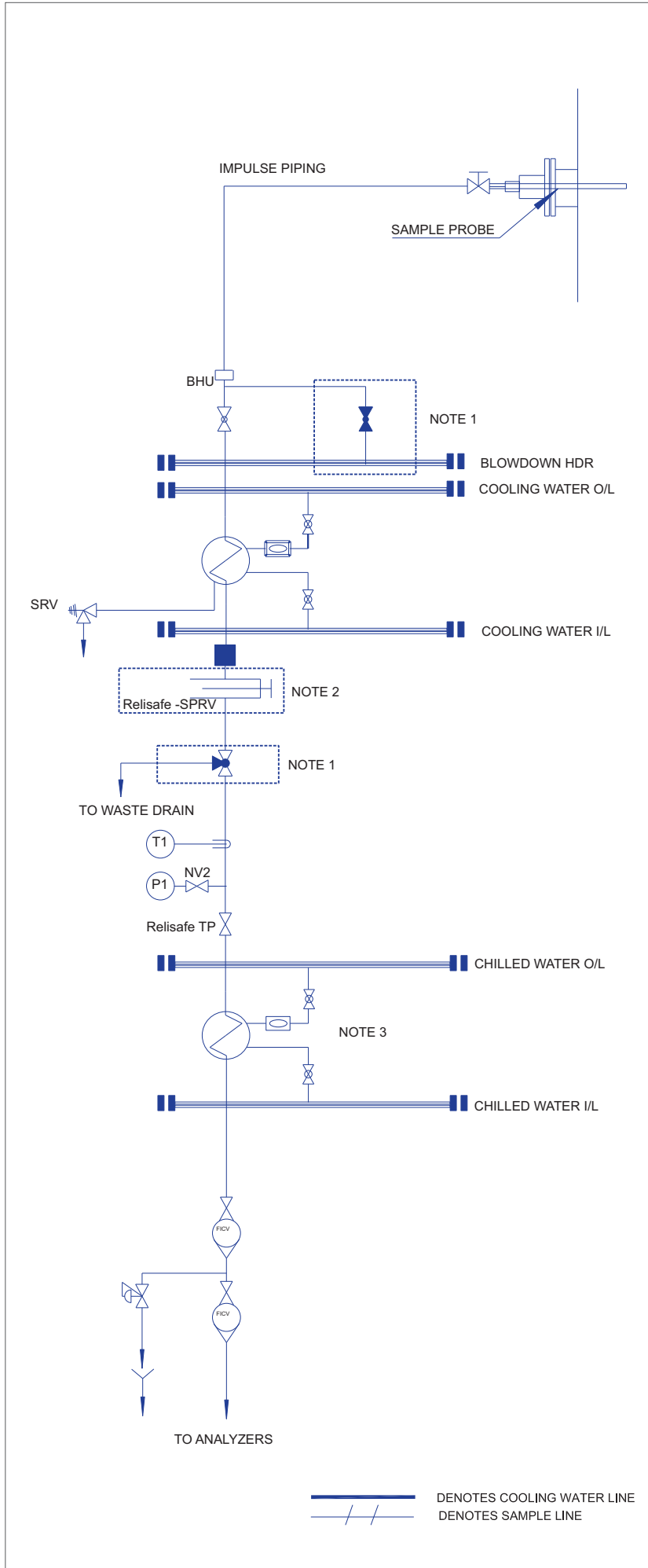

Item	Description
IV	Sample isolation valve (HT globe valve)
NV2	Needle valve for pressure gauge
SC	Primary sample cooler
BDV1	Blow down valve (HT globe valve)
BDV2	Blow down valve (Ball valve)
SG	Sight glass indicator
CV	Coolant isolation valve (Ball valve)
SF	Sample filter (40 micron fine filter)
SPRV	Sample pressure reducing valve (For pressure >35bar) (Relisafe-PR)
NV	Needle valve for pressure regulation
SRV	Safety relief valve
TG	Temperature gauge
PG	Pressure gauge
TP	High temperature safety shut off valve with manual reset (Relisafe-TP)
FICV	Rotameter with built in needle valve
TUNDISH	Tundish
BPR	Back pressure regulator
BHU	Bulkhead union

Option 1: BDV1: High temperature & high pressure blow down before primary cooler, as per VGB-0006 codes.

Option 2: BDV2: Low temperature & high pressure blow down after primary cooler As per standard ASME PTC 19.11-2008 edition.

Applicable for pressure higher than 35 bar.

Optional Secondary sample cooling.

## Some Important Components of Sampling Systems (Wet Rack)

### Sample Probe



Forbes Marshall, now brings you a profitable solution in the form of Isokinetic Probes, designed to meet the SWAS requirements as per ASTM D1066.

These probes are designed to extract saturated and superheated steam samples isokinetically at high temperatures and pressure, ensuring extraction of representative sample from process steam lines. This helps to take immediate actions on water chemistry.

### Sample Cooler



Forbes Marshall Sample Coolers are coil-in-shell type contra-flow heat exchangers. Validated by a premier institute like IIT Bombay, we are one of the few sample cooler manufacturers in the world offering a guaranteed performance. With in-house tests set-up for performance testing, world-class manufacturing and welding facilities, we offer one of the most trusted sample coolers in the power sector. Various options of coil materials such as Stainless Steel AISI 316 and Inconel 625 etc are available.

### Sample Pressure Reducing Valve



Forbes Marshall's Relisafe-PR is a rod-in-tube type pressure reducing device. It has a combined function of pressure reduction and flow modulation. As the high pressure sample is forced to pass through the narrow annular region between rod and tube, the frictional resistance causes the pressure drop while at same time modulating the flow.

### Back Pressure Regulator



Forbes Marshall offers back pressure regulators (BPR) to avoid low flow (or fluctuating flow) conditions to analyzers in case of grab sample valve operations. In the absence of such a device, the sample would flow to the grab sample line when the grab sample valve is opened. This can create low flow alarm conditions in samples going to analyzers.

A pressure regulator and back pressure regulator combination provides very stable pressure and flow conditions, thereby ensuring reliable, efficient and accurate analysis.

### Sample Filters



We also manufacture filters required to ensure particle-free samples. Particles of size up to 40 microns size can be filtered out. Forged stainless steel body and hexagonal cap help easy cleaning of the filter element.

### Relisafe-TP Temperature Safety Shutoff Valve with Manual Reset



The Relisafe-TP is a mechanical device which ensures over temperature protection in case of sample from cooler not getting cooled and crossing the limit of allowable temperature of analyzers.

We recommend the use of temperature safety off valve to block the high temperature samples which otherwise can damage the analyzer sensors that are delicate and costly.

### High Temperature Isolation Valves



These valves are easy to operate and can be used for most high pressure and temperature applications. The unique plug/seat geometry and stuffing box design allow these valves to operate for extended periods of time without gland leakage and passing. Valves are designed for PN 500 (Class 2500) and are offered for all ratings upto PN 500 and Class 2500. Body seat integral stellite is hard faced by a special automatic welding process. Unique non-rotating single piece spindle plug design guarantees long seat life as grinding between plug and seat is eliminated.

### Cation Column

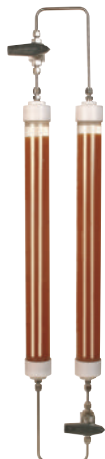

The duplex type cation conductivity column is a field proven design. Cation conductivity measurements are considered to be more reliable than ordinary conductivity measurements, as this method ensures elimination of masking effects of desired chemicals used in treating the water. This provides a more realistic picture of dissolved impurities in the sample. Our Cation Column is easy to operate, regenerate and maintain.

# Significance and Importance of Boiler Parameters

## Thermal Power Plant Steam and Water in-line Analytics

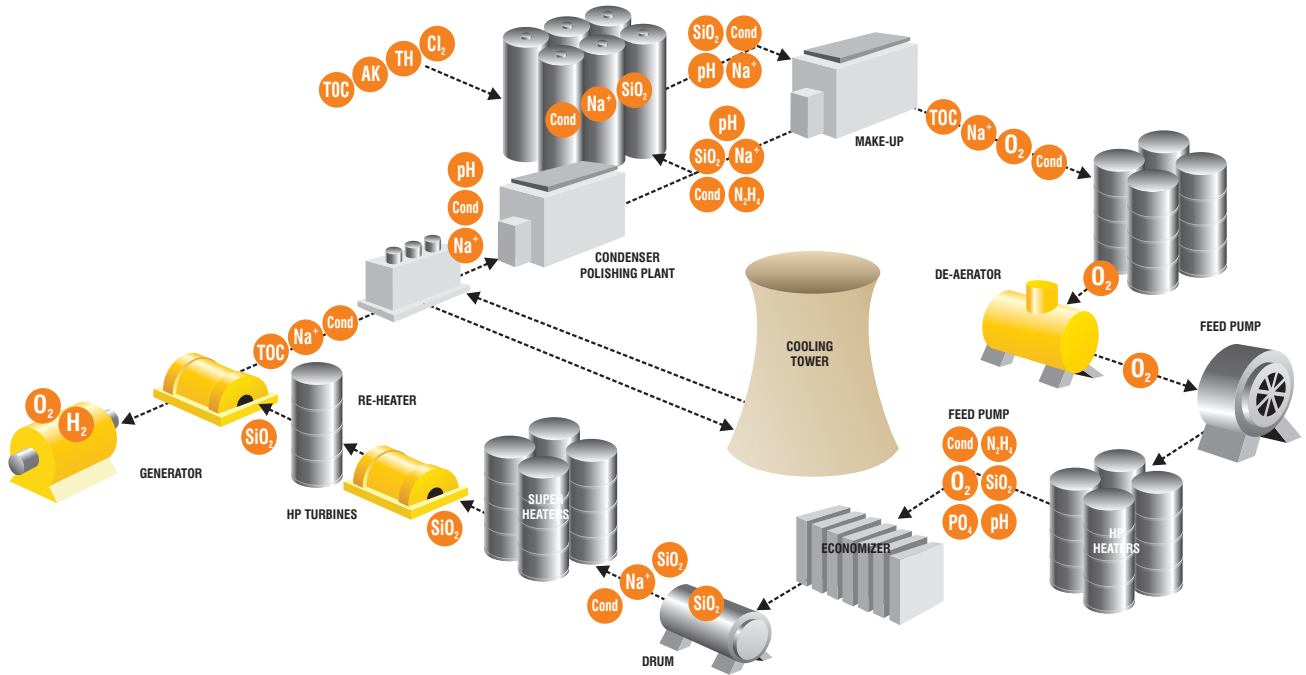

## Nuclear Cycle Measurement

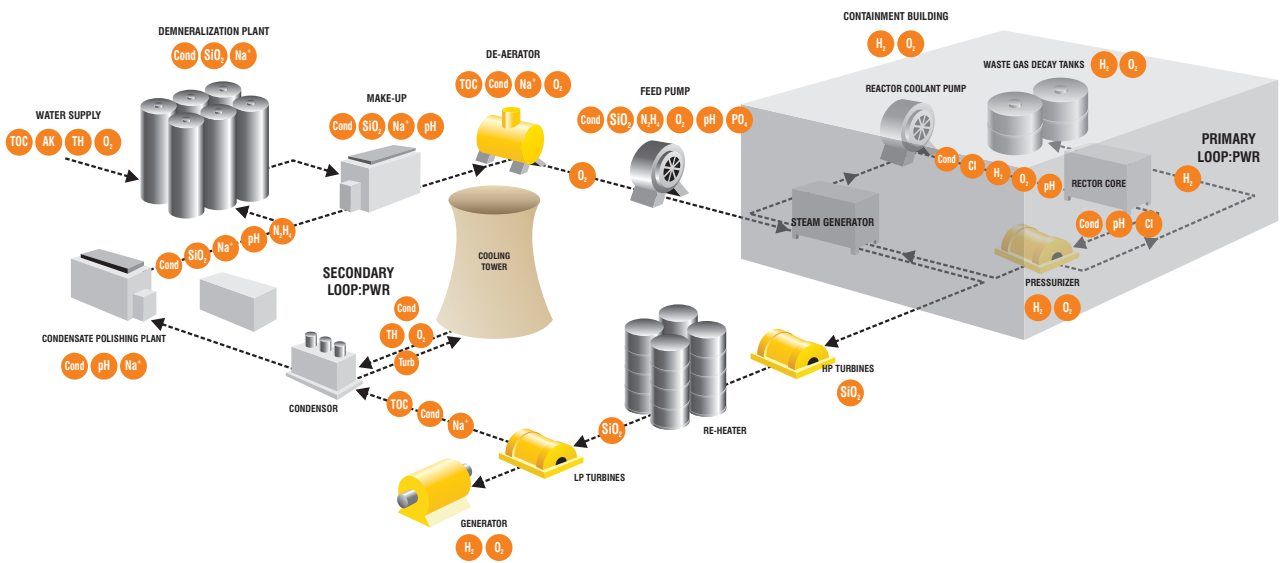

### AquaMon 2000 Pro Series



pH : The steam which goes to the turbines has to be ultra pure. The pH value of the feed water gives direct indication of alkalinity or acidity of this water. Ultra pure water has pH value of 7. In a steam circuit, it is a normal practice to keep the pH value of feed water at slightly alkaline levels. This helps in preventing the corrosion of pipe work and other equipment.

Typically dedicated pH analyzers are recommended at following locations in a steam circuit: high pressure heaters, DM make-up mater, condensate extraction pump discharge.

### AquaCon 2000 Pro Series



Conductivity: Conductivity is an important parameter for detecting any contamination of steam in the boiler circuit. Conductivity of pure water is almost zero (1-2  $\mu$  Siemens). Ingress of any kind of dissolved impurity will raise conductivity instantly. Thus conductivity is an important parameter for the detection of leakages.

Typical points in the steam circuit where conductivity should be monitored are: superheated steam, drum water, high pressure heaters, low pressure heaters, condenser, plant effluent, DM. plant, make-up water to DM. plant.

### Dissolved Oxygen



At elevated temperature, dissolved oxygen causes corrosion which may cause puncturing and failure of piping and components respectively. Dissolved oxygen also promotes electrolytic action between dissimilar metals causing corrosion and leakage at joints and gaskets. Mechanical deaeration and chemical scavenger additives are used to remove the dissolved oxygen. An analytical check of process efficiency, therefore, is essential. Dissolved oxygen monitoring is imperative in power stations using neutral or combined operating conditions (pH 7.0-7.5 or 8.0-8.5). The typical points in steam circuit where dissolved oxygen monitoring is required are deaerator inlet and outlet.

## Silica

The presence of silica in the steam and water circuits of a power generation plant is associated with a number of problems both in the super heater and turbine sections.

The solubility of silica in steam increases with pressure. Hence there are chances of silica carry over. The presence of silica in steam can lead to deposition in superheated tubes and on the turbine blades which may lead to loss of efficiency and turbine blade failure. For proper working of turbines, continuous monitoring of silica is highly recommended.

Thus the typical points in steam circuits where silica analysis is required are low level silica measurement in: high pressure and low pressure turbines, steam, drum (saturated) steam, CEP discharge, make-up water, DM. makeup water and high level silica measurement in drum water.

## Hydrazine

Hydrazine is used as an oxygen scavenger. So it also maintains feed water alkalinity to prevent acidic corrosion. It prevents frothing in the boiler and minimizes deposits on metal surfaces. Hydrazine also helps in maintaining a protective magnetite layer over steel surfaces. Underdosing of hydrazine leads to increased corrosion and overdosing represents a costly waste. Therefore hydrazine monitoring is extremely important. The typical points in a steam circuit where hydrazine monitoring is required are: re-heaters, economizer inlet and L.P. heaters.

## Sodium

The presence of sodium signals contamination with potentially corrosive anions, e.g. chlorides, sulfates etc. Under conditions of high pressure and temperature, neutral sodium salts exhibit considerable steam solubility. NaCl and NaOH, in particular, are known to be associated with "Stress Corrosion Cracking" of boiler and superheater tubes. The ubiquitous character of sodium in the environment makes it a useful indication to reveal possible "leak conditions" within the circuit, particularly in the condenser section where the measurement of sodium detects cooling-water leaks with a much higher sensitivity than conductivity measurements. The typical points in a steam circuit where sodium monitoring is required are: DM. plant make up water, condensate pump discharge, condenser, drum (saturated) steam.





### Chilled Package



Chilled water is required when the cooling water available at site is incapable of cooling the sample to the temperature required by the analyzers.

If cooling water temperature exceeds 400 Deg C, the sample temperature would exceeds 450 Deg C, which is higher than the temperature required by the analyzers. To bring down the temperature of the sample, chilled water is required.

A chiller package is also required when a sample is to be cooled at 25 Deg C. We manufacture these and are the only SWAS manufacturers with this capability.

### Lab Sampling Module

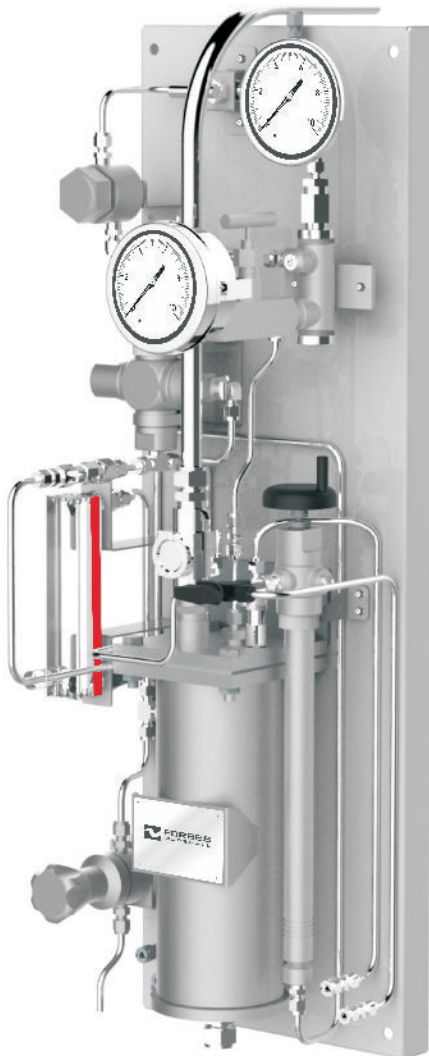

We offer the lab sampling module for laboratory analysis of steam in process boilers which is designed as per international standards. Its small and compact size and light weight design makes it suitable for continuous lab sample collection. It is easy to operate and can be fitted easily on site.

Wherever there is a boiler, a lab sampling module is required.

## Our Range

### Open Frame Dry Rack



### Dry Panel



### Chiller



### Enclosed Frame Wet Panel



## Our Range

### CTLDS System



### Primary Rack



### Cooling Isolation Skid

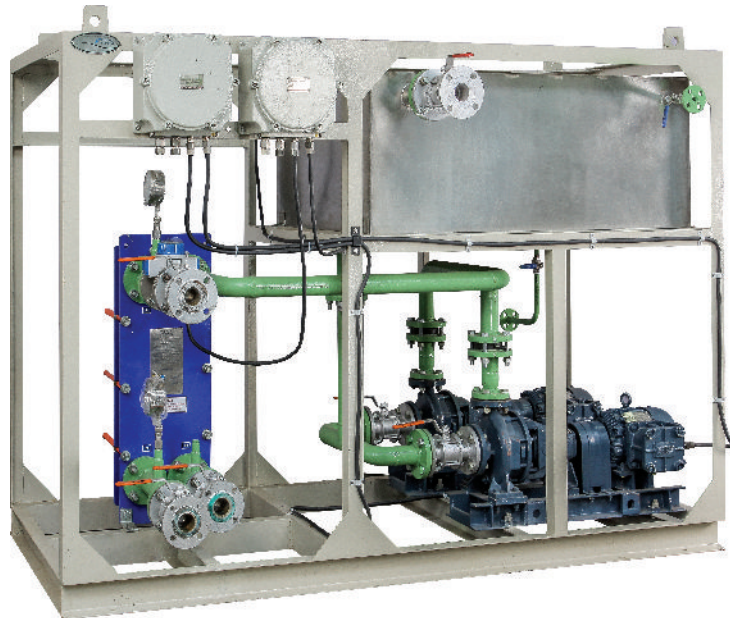

### SWAS in Shelter



## Global Installations



Forbes Marshall is the only SWAS manufacturer with unique expertise in both Steam Engineering and Control Instrumentation



Forbes Marshall  
Krohne Marshall  
Forbes Marshall Arca  
Codel International  
Forbes Solar  
Forbes Vyncke  
Forbes Marshall Steam Systems

Opp 106th Milestone  
Bombay Poona Road  
Kasarwadi, Pune - 411 034. INDIA  
Tel : 91(0)20-27145595, 39858555  
Fax : 91(0)20-27147413

Email : [swasmktg@forbesmarshall.com](mailto:swasmktg@forbesmarshall.com), [ccmidc@forbesmarshall.com](mailto:ccmidc@forbesmarshall.com)

B-85, Phase II, Chakan Indl Area  
Sawardari, Chakan, Tal. Khed  
Dist. Pune - 410 501. INDIA  
Tel : 91(0)2135-393400

A-34/35, MIDC H Block  
Pimpri, Pune - 411 018. INDIA.  
Tel : 91(0)20-27442020, 39851199  
Fax : 91(0)20-27442040  
CIN No.: U28996PN1985PTC037806  
[www.forbesmarshall.com](http://www.forbesmarshall.com)

© All rights reserved. Any reproduction or distribution in part or as a whole without written permission of Forbes Marshall Pvt Ltd, its associate companies or its subsidiaries ("FM Group") is prohibited.  
Information, designs or specifications in this document are subject to change without notice. Responsibility for suitability, selection, installation, use, operation or maintenance of the product(s) rests solely with the purchaser and/or user. The contents of this document are presented for informational purposes only. FM Group disclaims liabilities or losses that may be incurred as a consequence of the use of this information.